

Horizontal Electrophoresis Systems

Models FB-SB-710, FB-SB-1316, FB-SBR-1316, FB-SB-2025, FB-SBR-2025 and FB-SB-2318



Important Read this instruction manual. Failure to read, understand and follow the instructions in this manual may result in damage to the unit, injury to operating personnel, and poor equipment performance. ▲

Caution All internal adjustments and maintenance must be performed by qualified service personnel. ▲

Material in this manual is for information purposes only. The contents and the product it describes are subject to change without notice. Fisher Scientific makes no representations or warranties with respect to this manual. In no event shall Fisher Scientific be held liable for any damages, direct or incidental, arising out of or related to the use of this manual.

Statement of Proper Use: Use this product only for its intended purpose as described in this manual. Do not use this product if the power leads are damaged or if any of its surfaces are cracked.

Caution Running conditions for this unit should not exceed the name plate readings found on the lower buffer chamber. ▲

Caution Do not move the unit unless the power source to the unit has been disconnected. Further, the power supply must be equipped with a shut-down-on-disconnect circuit. ▲

This Electrophoresis System is designed to meet IEC 1010-1 safety standards (IEC 1010-1 is an internationally accepted electrical safety standard for laboratory instruments).

© 2020 Fisher Scientific. All rights reserved.



Important operating and/or maintenance instructions. Read the accompanying text carefully.



Potential electrical hazards. Only qualified persons should perform procedures associated with this symbol.



Equipment being maintained or serviced must be turned off and locked off to prevent possible injury.



Hot surface(s) present which may cause burns to unprotected skin, or to materials which may be damaged by elevated temperatures.



Marking of electrical and electronic equipment, which applies to electrical and electronic equipment falling under the Directive 2012/19/EU (WEEE) and the equipment that has been put on the market after 13 August 2005.

This product is required to comply with the European Union's Waste Electrical & Electronic Equipment (WEEE) Directive 2012/19/EU. It is marked with the WEEE symbol. Fisher Scientific has contracted with one or more recycling/disposal companies in each EU Member State European Country, and this product should be disposed of or recycled through them. Further information on Fisher Scientific's compliance with this directive, the recyclers in your country and information on Fisher Scientific products will be available at www.fishersci.com.

- ✓ Always use the proper protective equipment (clothing, gloves, goggles, etc.)
- ✓ Always dissipate extreme cold or heat and wear protective clothing.
- ✓ Always follow good hygiene practices.
- ✓ Each individual is responsible for his or her own safety.

Do You Need Information or Assistance on Fisher Scientific Equipment?

The Fisher Scientific Sales Group can provide information on pricing and give you quotations. We can take your order and provide delivery information on major equipment items or make arrangements to have your local sales representative contact you. Our products are listed on the internet and we can be contacted through our Internet home page.

1-800-766-7000
www.fishersci.com

Customer Service
To order online

Fisher Scientific Product Service Support can supply technical information about proper setup, operation or troubleshooting of your equipment. We can fill your needs for replacement parts or provide you with on-site service. We can also provide you with a quotation on our Extended Maintenance Program for our products.

Whatever products you need or use, we will be happy to discuss your applications. If you are experiencing technical problems, working together, we will help you locate the problem and, chances are, correct it yourself...over the telephone without a service call.

When more extensive service is necessary, we will assist you with direct factory trained technicians or a qualified service organization for on-the-spot repair. If your service need is covered by the Fisher Scientific Products warranty, we will arrange for the unit to be repaired at our expense and to your satisfaction.

Regardless of your needs, professional service technicians are available by telephone to assist you concerning our products Monday through Friday from 8:00 a.m. to 6:00 p.m. Eastern Time. Please call or fax us at:

1-800-766-7000
1-800-926-1166

Customer Service
Orders Fax

International customers, please contact your local Fisher Scientific distributor.

Table of Contents

Section 1	General Information	1-1
	Unpack and Check Your Order	1-2
Section 2	Setting Up	2-1
	Lid Installation	2-1
	Beginning Set-Up	2-2
	Gel Casting	2-2
	Leveling the Unit	2-3
	Preparing the Gel	2-3
Section 3	Using the System	3-1
Section 4	Technical Tips	4-1
	Reagent Information	4-1
Section 5	Troubleshooting	5-1
Section 6	Care and Cleaning	6-1
Section 7	Optional Equipment	7-1
	Accessories	7-1
	Combs and Well Volumes	7-2

Section 1 General Information

Note Complete comb information found in Section 7.

Model FB-SB-710 - This Horizontal Minigel Systems, is designed to provide flat, even banding patterns and consistent results with hassle-free gel casting. The all-in-one design allows you to cast and run gels in the same chamber, eliminating the need for additional casting equipment. No tape, grease, agarose seals or other accessories are required. This systems accommodate 2 comb positions, allowing the user to run 2 series of samples equal distances simultaneously.

Model FB-SB-1316 and FB-SBR-1316 (with recirculation) - This Large Horizontal System has the smallest footprint of the large format device giving you a space saving device for your extended runs. This system is ideal for detailed RNA / DNA analysis. The unit runs from 8 to 96 samples on one gel.

A wall comb is available for running shorter gels and conserving agarose. A programmable power inverter may be used for field reversal electrophoresis.

Model FB-SB-2025 and FB-SBR-2025 (with recirculation) This Large Horizontal System is a simple, convenient and fast system for detailed DNA/RNA analysis on multiple samples. This system offers the widest variety of comb options and when used with a wall comb you can cast varying length gels to conserve agarose.

Model FB-SB-2318 - This Large Wide Gel Horizontal System offers a simple, convenient and fast method for screening multiple samples on a single agarose gel. Ideal for screening PCR samples, plasmid preps, restriction mapping and cloning. 25 to 200 samples can be run simultaneously on one gel; producing clear, tight banding patterns with no “smiling”. This model has an external caster. The UVT gel tray is fitted with a gasket which allows the tray to fit snugly into the external gel caster to provide a leakproof seal without tape.

Model FB-SBR-1316 and FB-SBR-2025 Recirculation Systems offer convenience and versatility. The Recirculation System prevents formation of pH and ionic gradients for high resolution and uniform reproducible results. The Recirculation System is ideal for long runs, multiple sample sets or RNA gels. It delivers clear results for samples run over long time periods. It also eliminates uneven migration, band distortion or disassociation of pH dependent glyoxylated RNA molecules that can result when ionic depletion occurs. Because the recirculation system is built right into the buffer chamber, no external pumps, tubing or stir bars are required.

Unpack and Check Your Order

Before starting, unpack the unit and inventory your order. If any parts are missing, refer to the enclosed information sheet regarding returns and exchanges and contact Technical Services immediately.

Reference the order or catalog number on your invoice and check the corresponding part lists:

FB-SB-710

1 buffer chamber, 1 safety lid with power cords, 1 UVT gel tray with 2 gaskets, 2 combs: 6 & 10-tooth, double-sided - 1.0 mm/1.5 mm thick

FB-SB-2318

1 buffer chamber, 1 safety lid with power cords, 1 UVT gel tray with 2 gasketed end gates, 5 microwell combs; 50 tooth, 1.5 mm thick

FB-SB-1316 and FB-SBR-1316

1 Buffer chamber, 1 safety lid with power cords, 1 UVT gel tray with 2 gaskets, 2 12-tooth combs - 1.5 mm thick, 2 20-tooth combs - 1.5 mm thick

FB-SB-2025 and FB-SBR-2025

1 Buffer chamber, 1 safety lid with power cords, 1 UVT gel tray with 2 gasketed end gates, 1 16-tooth comb -1.5 mm thick, 1 24-tooth comb - 1.5 mm thick, 1 36-tooth combs - 1.5 mm thick

Section 2 Setting Up

Lid Installation

1. Before installing the lid on to the gel box tank, loosen both the black and red power supply lock nuts on the lid, as shown in Figure 2-1 below.

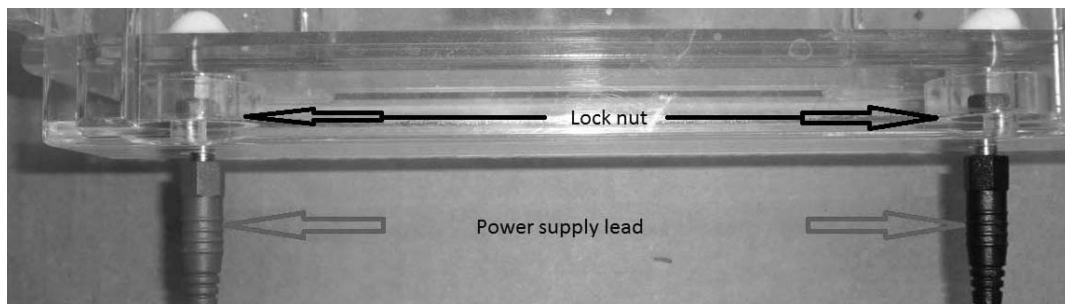

Figure 2-1. Black and Red Power Supply Locknuts

Note Failure to loosen the power supply leads before installing the lid can result in damage to the banana plugs, barrel cage and/or misalignment of the lid.

2. Install the lid, allowing the loosened power supply leads to self-align onto the banana plugs, as shown in Figure 2-2.

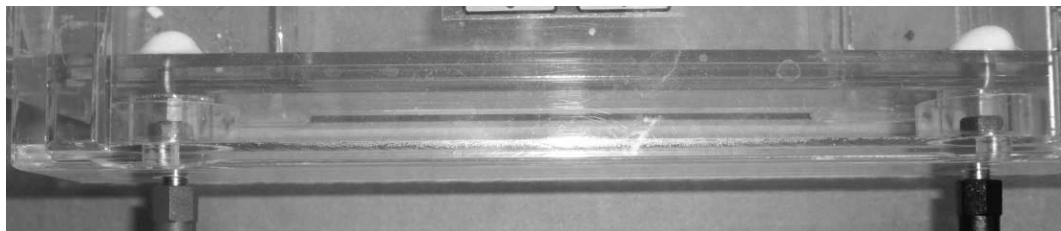

Figure 2-2. Allow the Leads to Align with Banana Plugs

3. Once the lid is installed and the power supply leads make contact with the banana plugs, turn the power supply leads, tightening the power supply lead lock nut, as shown below.

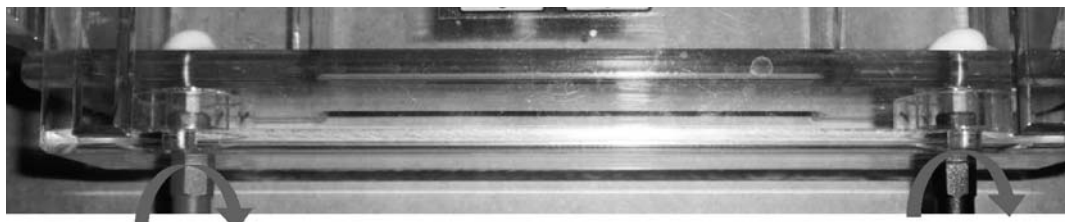

Figure 2-3. Turn the Power Supply Leads to Tighten Lead Locknut

Lid Installation (continued)

4. The above alignment procedure will need to be performed when:
 - Installing the lid onto the gel box for the first time.
 - After replacing the lid or gel box due to damage to originals
 - After replacing power supply leads

Note When running multiple Gel Box of the same model, DO NOT INTERCHANGE LIDS. Do not interchange lids without following the lid installation procedure.

Beginning Set-Up

1. Remove the lid from the buffer chamber. The lid is attached to the unit at the junction of the lids attached power supply leads to the banana plugs located on the unit. To remove, hold the pins with one finger and slide the lid off evenly by holding the center of the back of the lid.

2. GEL CASTING

FOR MODELS FB-SB-710, FB-SB-1316 and FB-SBR-1316:

For shipping and convenient storage, the gel tray is packaged inside the unit. To remove the gel tray, hold the unit firmly with one hand; grasp the long sides of the UVT gel tray and pull up slowly at an angle. The gel tray needs to fit snug for leakproof gel casting, so it may be somewhat tight. Walking "the tray upwards at an angle may be helpful". To cast gels (Figure 2-4), place the gel tray into the chamber so that the gasketed ends press against the walls of the buffer chamber. Make sure the gel tray is pressed all the way down and rests level on the unit's platform.



Figure 2-4. Gel Casting

FOR MODELS FB-SB-2025, FB-SBR-2025 and FB-SB-2318:

The tray for these models is packaged outside of the unit with the gasketed end gates in casting position. To ensure leak-free casting, check the end gates to be sure that they are firmly in their grooves with the gasket side facing outward. Use the built-in leveling feature to level the unit before pouring agarose.

To cast gels (Figure 2-5), slide the gasketed end gates into the outermost grooves on either side of the gel tray. The end gates should be inserted tightly into the grooves with the gasket side facing out. Place the UVT gel tray into the buffer chamber making sure the gel tray rests level and centered on the platform.

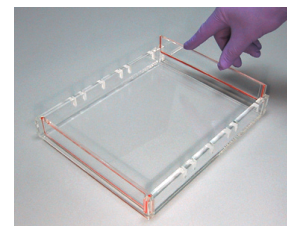

Figure 2-5. End Gate

Beginning Set-Up (continued)

3. LEVELING THE UNIT

When running larger size gels, it is important to cast and run a level gel for consistent reproducible results. Level the unit using the thumbscrews on each side of the front of the unit by slowly turning one thumbscrew at a time and lining up the bubble in the level with the center circle (the rear screw is for stability only)

4. PREPARING THE GEL

The percentage of agarose and the buffer used is determined by the size of the samples to be separated and further recovery of the samples. The agarose and buffer are mixed and heated over a heat source, in a microwave oven, or in an autoclave until the agarose is completely dissolved. The prepared gel then must be cooled to below 60° before casting to avoid warping the UVT gel tray due to excessive heat. If numerous gels are to be run in one day, a large volume of gel may be prepared and be placed in a covered bottle stored between 40-60° in a water bath. This provides a ready gel supply in a warm liquid form that will solidify quickly when gels are cast.

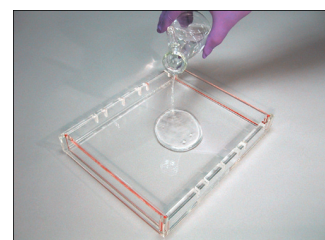

Figure 2-6. Preparing Gel

5. Pour or pipette the correct amount (see Table 4-2) of warm agarose (<60°C) onto the UVT gel tray that has been placed into position in the gel box. Immediately after pouring, insert the desired comb or combs into the comb slots to form the sample wells. If only a small portion of gel is required for proper sample separation, multiple combs may be used to run 2, 3, 4, 5 or 10 sets (depending on model) of equal distance samples simultaneously expanding the number of samples per gel that may be run. To conserve agarose, a wall comb may also be used to divide and use a smaller portion of the length of the gel tray. If a wall comb is used, pipette a bead of agarose along the bottom and side edges of the wall comb once it has been placed in the tray to seal the combs edges to the trays bottom and sides. Once this bead is solidified, the cooled gel may be poured as described. Alternately, regular tape cut slightly longer than the comb can be placed flat along the combs surface and the comb angled into place in the gel tray. Extra tape is then placed on the outside of the comb in the excess tray area to reinforce the corners. Allow the gel to solidify completely.

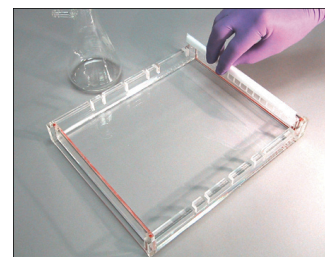

Figure 2-7. Wall Comb

Section 2
Setting Up

Section 3 Using the System

FOR MODEL FB-SB-710 & FB-SB-1316

1. Once the gel is completely solidified, lift the tray out of the chamber, turn it 90°, and replace it in the chamber with the first comb closest to the cathode side of the chamber. This running position exposes the open ends of the agarose to the buffer.
2. Pour running buffer into the unit to fill chamber and completely cover and submerge the gel. See Recommended Running Conditions on page 11 for approximate buffer volumes needed for your unit. Too little buffer may cause the gel to dry out during the run, while excess buffer may slow DNA migration in the gel.
3. Carefully remove the comb (or combs) by tapping lightly to loosen, and slowly lifting out of the gel tray to avoid damage to the wells.
4. Load prepared samples into the wells (See Table 4-1). Samples should be mixed with a sample loading buffer; giving weight to the samples so that they drop evenly into the wells, and contain tracking dye to monitor the gel run. See available comb section for approximate well volumes.
5. Place the lid with attached power cords onto the unit. This will connect the power cords to the banana plug electrodes and complete the circuit. Plug the other end of the power cords into appropriate power supply.
6. Turn on the power supply (See Table 3-1. Recommended Running Conditions). Carefully monitor the gel run to avoid samples running into the path of another set of samples.

FOR MODEL FB-SB-2025, FB-SB-2318 & FB-SBR-2318

1. Once the gel is completely solidified, carefully loosen and remove the gasketed end gates from the ends of the tray.
2. Pour running buffer into the unit to fill chamber and completely cover and submerge the gel. See Table 3-1 for approximate buffer volumes needed for your unit. Too little buffer may cause the gel to dry out during the run, while excess buffer may slow DNA migration in the gel.

FOR MODEL FB-SB-2025, FB-SB-2318 & FB-SBR-2318 (continued)

3. Carefully remove the comb (or combs) by tapping lightly to loosen, and slowly lifting out of the gel tray to avoid damage to the wells.
4. Load prepared samples into the wells (See Table 5-2, page 13). Samples should be mixed with a sample loading buffer; giving weight to the samples so that they drop evenly into the wells, and contain tracking dye to monitor the gel run. See available comb section for approximate well volumes.
5. Place the lid with attached power cords onto the unit. This will connect the power cords to the banana plug electrodes and complete the circuit. Plug the other end of the power cords into appropriate power supply.
6. Turn on the power supply (See page 11 for Recommended Running Conditions). Carefully monitor the gel run to avoid samples running into the path of another set of samples.

SELF-CIRCULATING MODELS FB-SBR-1316 & FB-SBR-2025

The Fisherbrand Self-recirculating Systems allow for the recirculation of buffer without the need for a separate recirculator or accessories. Bubbles are captured on the cathode electrode and travel up a tube to the anode side of the gel box. These bubbles slowly displace the buffer creating an effective recirculation within the chamber. This system prevents the formation of pH and ionic gradients, uneven band migration and band distortion.

FOR MODEL FB-SB-1316R

1. Once the gel is completely solidified, lift the tray out of the chamber, turn it 90°, and replace it in the chamber with the first comb closest to the cathode (black) side of the chamber. This running position exposes the open ends of the agarose to the buffer.
2. PRIMING THE UNIT:

Fill the buffer chamber with enough buffer to fill both compartments, and allow it to stand for about 15 minutes prior to running. Fill the chamber at the cathode end (black electrode) first. This will flush out trapped air in the hydrogen collector and recirculation tube.

(continued)

FOR MODEL FB-SB-1316R (continued)

Priming the unit is most important when using buffers of low ionic strength (like TAE or NaPO₄). This process minimizes the electrostatic repulsion between the hydrogen gas bubbles and the recirculation tube's surface. Neglecting this step may result in decreased efficiency of the recirculation system.

3. Pour running buffer into the unit to fill chamber and completely cover and submerge the gel. See Table 3-1 Recommended Running Conditions for approximate buffer volumes needed for your unit. Too little buffer may cause the gel to dry out during the run, while excess buffer may slow DNA migration in the gel.
4. Carefully remove the comb (or combs) by tapping lightly to loosen, and slowly lifting out of the gel tray to avoid damage to the wells.
5. Load prepared samples into the wells (See Table 4-2). Samples should be mixed with a sample loading buffer; giving weight to the samples so that they drop evenly into the wells, and contain tracking dye to monitor the gel run. See available comb section for approximate well volumes.
6. Place the lid with attached power cords onto the unit. This will connect the power cords to the banana plug electrodes and complete the circuit. Plug the other end of the power cords into appropriate power supply.
7. Turn on the power supply (See Table 3-1). Carefully monitor the gel run to avoid samples running into the path of another set of samples.

FOR MODEL FB-SBR-2025

1. Once the gel is completely solidified, loosen and remove the gasketed end gates, and place the gel tray in the buffer chamber with the first comb closest to the cathode (black) side of the chamber. This running position exposes the open ends of the agarose to the buffer.
2. PRIMING THE UNIT:

Fill the buffer chamber with enough buffer to fill both compartments, and allow it to stand for about 15 minutes prior to running. Fill the chamber at the cathode end (black electrode) first. This will flush out trapped air in the hydrogen collector and recirculation tube.

FOR MODEL FB-SBR-2025 (continued)

Priming the unit is most important when using buffers of low ionic strength (like TAE or NaPO₄). This process minimizes the electrostatic repulsion between the hydrogen gas bubbles and the recirculation tube's surface. Neglecting this step may result in decreased efficiency of the recirculation system.

3. Fill the chamber with running buffer until the gel is completely submerged. Three to five millimeters of buffer above the gel is sufficient. See Table 3-1 for approximate buffer volumes needed for your unit. The buffer volume can vary and is partly determined by the thickness of the gel. Too little buffer may cause the gel to dry out during the run, while excess buffer may slow DNA migration in the gel.
4. Carefully remove the comb (or combs) by tapping lightly to loosen, and slowly lifting out of the gel tray to avoid damage to the wells.
5. Load prepared samples into the wells (See Table 4-2). Samples should be mixed with a sample loading buffer; giving weight to the samples so that they drop evenly into the wells, and contain tracking dye to monitor the gel run. See Combs and Well Volumes in Section 7, for approximate well volumes.
6. Place the lid with attached power cords onto the unit. This will connect the power cords to the banana plug electrodes and complete the circuit. Plug the other end of the power cords into appropriate power supply.
7. Turn on the power supply, see Table 3-1. Carefully monitor the gel run to avoid samples running into the path of another set of samples.

FOR ALL MODELS

When the gel run is complete and tracking dye has migrated as far through the gel as desired or to the end of the gel, turn off the power supply and slide off the lid to disconnect from the power source. Carefully remove the tray containing the gel (wear gloves if ethidium bromide is present). The UV transparent gel tray makes visualization and photography with a UV light source easy without the need to remove the gel from the tray.

It is wise to always run a sample lane of a known “standard ladder” to determine concentration and size of separated fragments after the gel run, and to aid in photo documentation and analysis.

Table 3-1. RECOMMENDED RUNNING CONDITIONS

	FB-SB-710	FB-SB-1316	FB-SBR-1316	FB-SB-2025	FB-SBR-2025	FB-SB-2318
Gel Size (W x L in cm)	7 x 10	13 x 16	13 x 16	20 x 25	20 x 25	23 x 18
Buffer Capacity (ml)	300	1000	1200	2300	2000	1200
Voltage Requirements (V)	20-150	20-150	20-150	20-250	20-250	20-250
Time in Minutes	30-60	45-90	45-8hrs. or more	45-120	45-8hrs	30 - 60

Section 3
Using the System

Section 4 Technical Tips

REAGENT INFORMATION

There are various types of agarose commercially available that may be used. Besides standard ultra pure electrophoresis grade agarose, there are also numerous low melting point products for easy sample recovery, as well as speciality products formulated for specific uses to separate/recover very small or very large fragments etc.

To visualize and photograph the samples after the gel run for a permanent record, the gel may be stained during or following the run with a variety of stains. The most common stain for DNA is ethidium bromide. Ethidium bromide may be added directly to the gel and running buffer to quickly and easily visualize and photograph the separated fragments following the gel run without the need for additional staining. If this is not added, then following the gel run, the gel may also be soaked in a concentrated ethidium bromide solution and rinsed for the same visualization. The ethidium bromide is added to both the gel (after heating) and the electrophoresis buffer at a concentration of 0.5 g/ml.

Ethidium bromide is a potential carcinogen. Care in handling the powder and stock solution must be taken. Always wear gloves when handling the powder, solutions and all gels that contain any amount of ethidium bromide.

Table 4-1. Mobility range of DNA in different percentage agarose gels

Agarose % (w/v)	Approximate range of separated DNA fragments (kb)
0.3	60 to 5
0.5	30 to 1
0.7	12 to 0.8
1.0	10 to 0.5
1.2	7 to 0.3
1.5	4 to 0.2
2.0	3 to 0.1
3.0	< 0.1

It should be noted, an increased agarose % gives better separation of small fragments and also bands very close together that tend to be more difficult to separate, visualize and photograph. A specialty agarose product formulated to increase resolution of low molecular mass samples may also be used.

Example: A good mid range gel percentage would be 0.7%, or 0.7 g agarose in 100 mls electrophoresis buffer (TBE or TAE), following heating and dissolving the agarose, 10 ml of ethidium bromide stock solution (5 mg/ml) is added. The gel would be run with compatible electrophoretic running buffer (1X TBE or 1X TAE) that also contained ethidium bromide 1 liter of the running buffer would contain 100 µl of this 5 mg/ml ethidium bromide stock solution.

Preparation & Properties of TAE and TBE Electrophoresis Buffer Systems:

These buffers are used because they both have a basic pH which gives the phosphate group of the DNA a net negative charge allowing migration of the DNA toward the positive anode in the electrophoresis chamber.

TAE - Tris acetate w/ EDTA - (40 mM Tris base 40 mM acetic acid, 1 mM EDTA)

50X stock solution, pH ~8.5:

242 g Tris base
57.1 ml glacial acetic acid
18.61 g Na₂EDTA - 2H₂O (MW 372.24)
Distilled H₂O to 1 liter final volume

1X working solution:

40 mM Tris acetate
1 mM EDTA

TBE - Tris borate with EDTA — (89 mM Tris base, 89 mM boric acid, 2 mM EDTA)

10X stock solution:

108 g Tris base
55 g boric acid
7.44 g Na₂EDTA - 2H₂O (MW 372.24)
(or 40 ml 0.5 M EDTA, pH 8.0)

1X working solution:

89 mM Tris base
89 mM boric acid
2 mM EDTA

Distilled H₂O to 1 liter final volume

Do not adjust pH

Buffer: TAE Buffer

Suggested Uses and Comments: Use when DNA is to be recovered; For electrophoresis of large (>20 kb) DNA; Applications requiring high resolution; Has low ionic strength and low buffering capacity - recirculation may be necessary for long runs (>4 hrs.).

Buffer: TBE Buffer

Suggested Uses and Comments: For electrophoresis of small (<1 kb) DNA; Better resolution of small (<1 kb) DNA; Decreased DNA mobility; High ionic strength and high buffering capacity - no recirculation needed for extended run times. TBE buffer reacts with the agarose making smaller pores and a tighter matrix. This reduces broadening of the DNA bands for sharper resolution.

Ethidium Bromide - is ideal for the fluorometric detection of nucleic acids in gel electrophoresis. The addition of ethidium bromide to both the prepared gel and running buffer is a convenient way to monitor separation and keep a photographic log of gel runs. Ethidium Bromide is prepared as 10 mg/ml in distilled water and used as a stock working solution of 5.0 µg/ml in the electrophoresis buffer and gel. Mix ethidium bromide powder or tablet thoroughly into solution checking for any precipitate and store at room temperature protected from light.

Amount of Agarose to prepare: Gel volume is determined by the following formula and may be adjusted according to need or preference:

Table 4-2. Agarose gel amounts

Amount of Agarose			
gel width (cm) x gel length (cm) x gel thickness (cm) = ml of agarose			
Model #	Gel size (cm)	Thickness of 0.25 cm	Thickness of 0.50 cm
FB-SB-710	7 x 10	17.5 ml	35 ml
FB-SB-1316 and FB-SBR-1316	13 x 16	52 ml	104 ml
FB-SB-2318	23 x 18	103.5	207
FB-SB-2025 and FB-SBR-2025	20 x 25	125 ml	250 ml

Agarose Gel Loading Buffer

Samples are prepared and combined with gel loading buffer before being applied to the prepared gel. Sample buffer usually contains similar components to the running buffer, dyes for visibility, and glycerol to provide some weight to the samples. This increased sample density and color allows easy visualization of the samples and ensures samples load evenly into the wells and do not float out during loading. Dyes also migrate toward the anode end of the electrophoresis chamber at predictable rates allowing the gel run to be monitored.

The most commonly used loading buffer is glycerol, bromophenol blue, and xylene cyanol.

WHY RECIRCULATE BUFFER?

During electrophoresis, gradual ionic depletion of the running buffer forms an ionic and pH gradient across the system (acetate and phosphate buffers are especially prone to ionic depletion). Such gradients can cause uneven migration and banding patterns or cause pH-dependent glyoxylated RNA molecules to disassociate. Buffer recirculation ensures uniform ionic strength throughout the system.

Comparison Of Buffer pH With And Without Recirculation During Agarose Gel Electrophoresis

50 mg samples of HindIII digested DNA were run on duplicate gels, with and without buffer recirculation. pH measurements were taken at the anode and cathode ends at various time intervals and plotted against time. Running condition: 1% agarose gel in 10 mM NaH₂PO₄, pH 7.0, 114 V, constant voltage.

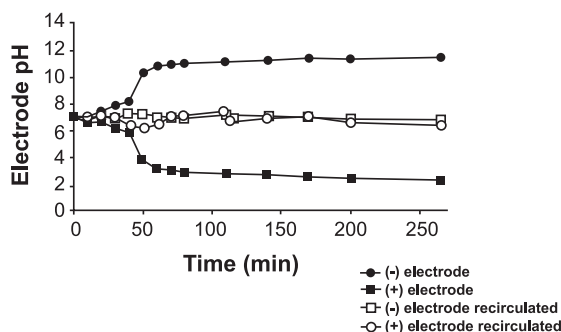

Figure 4-1. Comparison Chart

Sample Well / Comb Configuration

Hg = height of gel used

Hs = height of well used for sample volume

Hw = well height

How To Determine Well Sample Volume:

There are two volumes to consider when determining the sample volume for a horizontal gel.

- 1) Gel volume, which is Width x Length x Gel Height and uses centimeters and
- 2) Sample volume which is Tooth Width x Comb Thickness x Apparent Well Height, and uses millimeters.

Gel height is generally set to a height between 0.25 cm and 1.0 cm. Therefore, once you choose the height, the volume is the gel dimensions given in the catalog for each gel box (I.D.) times this height. Once the gel height (Hg) is chosen, the well volume and then the sample volume can be calculated. The well height (Hw) is 1.5 mm less than the gel height:

$H_w = \text{Gel Height} - 1.5 \text{ mm}$
Using the well height, the volume of the well is calculated:
 $V_w = (\text{Well Height}) (\text{Tooth width} \times \text{comb thickness})$.

The loading volume is a 0.75 safety factor applied to the well volume: $V_s = (V_w) (0.75)$

For Fisherbrand combs, there are two thicknesses, 1.0 mm and 1.5 mm. This is the depth. The width of the well is determined by the number of teeth. For a given gel box, as the number of teeth increase, the volume of each tooth decreases.

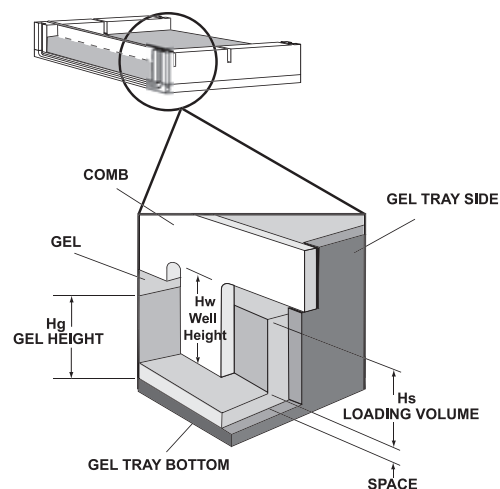

Figure 4-2. Well Source Volume

Section 4
Technical Tips

Section 5 Troubleshooting

Problem	Solution
Agarose leaks into chamber when casting the gel	Check to see if gasket is correctly seated in groove and even all the way around. Remove gasket and reseal by smoothing out gently with your thumb from one end to the other. After each use, rinse the end gates under warm running water to bring back sponge-like consistence of the gasket material. Gaskets may eventually become brittle with frequent use. Contact Technical Services to purchase replacement gaskets.
	Check to make sure gasketed end gates have been placed with in UVT gel tray with gaskets facing out.
Bands seem to be running at an angle.	Check to be sure that the unit is properly leveled for casting and running the gel by using the front thumbscrews on the base. Thumbscrews should be adjusted until the bubble in the level lines up with the levels center circle. Always center the gel tray holder on the platform and cool the agarose to below 60°C before pouring to avoid warping the UVT gel tray.
Samples seem to be running unevenly in certain areas.	Check that the platinum electrode wire is intact, running flat and evenly across the outer corners and up the side to the junction of the banana plug area. This problem could also be caused by regular casting with very hot agarose gel (>60°C) which may damage the gel tray over time. Always cool the melted agarose to below 60°C before casting to avoid warping the UVT gel tray. Warping the UVT gel tray will cause all subsequent gels to be cast unevenly.
Samples do not band sharply and appear diffuse in the gel.	Gels should be allowed to solidify completely before running. For standard agarose, this would be about 30 minutes, if low melting point agarose is used, it may be necessary to completely solidify gels at a cooler temperature in the refrigerator or cold room. Gels should be submerged in 3-5 mm of buffer to avoid gel dry out, but excess buffer >5 mm can cause decreased DNA mobility and band distortion.
Bands are not sharp, clear, and even.	Always follow proper procedure for preparing the agarose product according to manufacturers instructions. When preparing the agarose, be sure all the agarose powder is in solution before heating. In general, add powdered agarose to distilled water and swirl to mix. Make sure all the powder is equally wet to ensure proper melting. Heat in a microwave oven, boiling water bath, or hot plate with occasional swirling to melt and mix completely. Cool agarose liquid to below 60° and cast. Note High percentage gels may thicken and solidify rapidly and should be cast while still a liquid.

Problem	Solution
Samples are not moving as expected through the gel, remaining in the wells, or diffusing into the gel.	Check that a complete power circuit is achieved between the unit and the power supply. Platinum wire and banana plugs should be intact. To test, simply fill the unit with running buffer and attach to the power supply without a gel or gel tray in the unit. The platinum wires on both sides of the unit should produce small bubbles as the current passes through. If a complete circuit does not exist there will be few to no bubbles. Contact Technical Services to schedule a repair.
When the comb is removed from the gel some sample wells are ripped and damaged	Always make sure to allow the gel to solidify completely before moving the gel tray, unit, or removing the comb. To avoid damage to the sample wells, gently rock the comb back and forth lightly to loosen, then slowly pull the comb straight up out of the gel tray. This rocking helps to avoid suction as the comb is removed. Alternatively, once casting is complete, simply submerging the gel with running buffer will help loosen the comb. Using a higher percentage of agarose that forms a tighter gel matrix may remedy this problem as well.
The gel seems to run slower under the usual running conditions	The volume of running buffer used to submerge the gel should only be between 3-5 mm over the gel surface. Gel should be completely submerged to avoid the gel from drying out, which can smear the bands and possibly melt the gel due to overheating. If excessive running buffer is added the mobility of the DNA decreases and band distortion may result. Excess buffer causes heat to build up and buffer condensation inside the unit may result.

Additional Sources for Reference

Maniatis T., E. F. Fritsch and J. Sambrook. *Molecular Cloning: A Laboratory Manual*, Cold Spring Harbor Laboratory, Cold Spring Harbor, NY.

Short Protocols in Molecular Biology, - A Compendium of Methods from Current Protocols in Molecular Biology, Edited by Fredrick M. Ausubel, et. al.

Adams, D., and R. Ogden, *Electrophoresis in Agarose and Acrylamide Gels*, *Methods in Enzymology*, Vol. 152 (1987) Academic Press, Inc.

Fotador, U.S. Simultaneous Use of Standard and Low-Melting Agarose for the Separation and Isolation of DNA by Electrophoresis, *BioTechniques*, Vol. 10, No. 2, (1991)

Boots, S. Gel Electrophoresis of DNA ; *Analytical Chemistry*, Vol. 61, No. 8, April 15, 1989

Section 6 Care and Cleaning

A few tips about caring for your system follow.

Caution Organic solvents cause acrylic to “craze” or crack. Clean all acrylic systems with warm water and a mild detergent. Do not use ethanol or other organic solvents to clean these products. Do not autoclave, bake, or microwave your unit. Temperatures over 50°C can damage the acrylic. ▲

Note If an RNase free electrophoresis system is desired, there are various methods to rid the system of RNA contamination. For fast and easy decontamination, use RNase[®] Away. Spray, wipe or soak labware with RNase Away[®] then wipe or rinse the surface clean; it instantly eliminates RNase[®]. RNase[®] Away[®] eliminates the old methods that include treatment with 0.1% Diethyl Pyrocarbonate (DEPC) treated water and soaking in dilute bleach. DEPC is suspected to be a carcinogen and should be handled with care. This electrophoresis system should never be autoclaved, baked, or placed in a microwave.

To order RNase[®] Away at www.thermofisher.com:

Part Number

10328011250 ml bottle

Section 6

Care and Cleaning

Care of Acrylic

The following chemical compatibility chart is supplied for the convenience of our customers. Although acrylic is compatible with most solvents and solutions found in the biochemical laboratory, some solvents can cause substantial damage. Keep this chart handy to avoid harm to your apparatus by the use of an inappropriate solvent.

Codes:

S - Safe (No effect, except possibly some staining)

A - Attacked (Slight attack by, or absorption of, the liquid)
(Slight crazing or swelling, but acrylic has retained most of its strength)

U - Unsatisfactory (Softened, swollen, slowly dissolved)

D - Dissolved (In seven days, or less)

This list does not include all possible chemical incompatibilities and safe compounds. Acrylic products should be cleaned with warm water, a mild detergent such as Alconox™, and can also be exposed to a mild bleach solution (10:1). In addition, RNase removal products are also safe for acrylic

Table 6-1. Chemical Compatibility for Acrylic-Based Products

Chemical	Code	Chemical	Code	Chemical	Code
Acetic acid (5%)	S	Ethyl alcohol (50%)	A	Naptha	S
Acetic acid (Glacial)	D	Ethyl alcohol (95%)	U	Nitric acid (10%)	S
Acetic Anhydride	A	Ethylene dichloride	D	Nitric acid (40%)	A
Acetone	D	Ethylene glycol	S	Nitric acid concentrate	U
Ammonia	S	2-Ethylhexyl Sebacate	S	Oleic acid	S
Ammonium Chloride (saturated)	S	Formaldehyde (40%)	S	Olive oil	S
Ammonium Hydroxide (10%)	S	Gasoline, regular, leaded	S	Phenol 5% solution	U
Hydroxide (10%)	S	Glycerine Heptane (commercial grade)	S	Soap solution (Ivory)	S
Ammonium Hydroxide concentrate	S	Hexane	S	Sodium carbonate (2%)	S
Aniline	D	Hydrochloric acid (10%)	S	Sodium carbonate (20%)	S
Benzene	D	Hydrochloric acid concentrate	S	Sodium chloride (10%)	S
Butyl Acetate	D	Hydrochloric acid (40%)	U	Sodium hydroxide (1%)	S
Calcium chloride (saturated)	S	Hydrogen peroxide (3% solution)	S	Sodium hydroxide (10%)	S
Carbon tetrachloride	U	Hydrogen peroxide (28% solution)	U	Sodium hydroxide (60%)	S
Chloroform	D	Isooctane	S	Sodium hydrochlorite (5%)	S
Chromic acid (40%)	U	Isopropyl alcohol (100%)	A	Sulfuric acid (3%)	S
Citric acid (10%)	S	Kerosene (no. 2 fuel oil)	S	Sulfuric acid (30%)	S
Cottonseed oil (edible)	S	Lacquer thinner	D	Sulfuric acid concentrate	U
Detergent Solution (Heavy Duty)	S	Methyl alcohol (50%)	A	Toluene	D
Diesel oil	S	Methyl alcohol (100%)	U	Trichloroethylene	D
Diethyl ether	U	Methyl Ethyl Ketone	U	Turpentine	S
Dimethyl formamide	U	Methylene chloride	D	Water (distilled)	S
Diocetyl phthalate	A	Mineral oil (white)	S	Xylene	D
Ethyl acetate	D				

Section 6
Care and Cleaning

Section 7 Optional Equipment

ACCESSORIES

Comb volumes are calculated based on a gel thickness of 5 mm. If your gel is thinner or thicker, use this formula for calculation: $\text{Tooth width (mm)} \times \text{Tooth thickness (mm)} \times (\text{Gel thickness} - 1.5 \text{ mm})(\text{mm}) = \text{Total well volume in microliters.}$

Note Usual loads will be 75% of total well volume. If an excessive volume is loaded, the sample will overflow and contaminate adjacent wells.

Description	FB-SB-710	FB-SB-1316 FB-SBR-1316	FB-SB-2025 FB-SBR-2025	FB-SB-2318
UVT Gel Tray	FB-SB-730	FB-SB-1320	FB-SB-2530	FB-SB-2328
Casting Chamber-trays	FB-SB-732 (Max. 3 UVT Gel Trays)	FB-SB-1322 (Max. 2 UVT Gel Trays)		
Leveling Platform	FB-SB-1323	FB-SB-1323		
Replacement Gasket		FB-SB-1321	FB-SB-731	OWA3GK1
Wall Combs for Shorter Gels		FB-SB-1337	FB-SB-2555	OWD3WALL
Lid Assembly	FIS-710-LID	FIS-1316-LID	FIS-2025-LID	FIS-2318-LID

COMBS AND WELL VOLUMES

* Included standard with unit

Model #	Catalog #	# of Teeth	Tooth Thickness(mm)	Tooth Width(mm)	Well Volume (ul)
FB-SB-710	FB-SB-733	5	1.0	11	38
	FB-SB-734	5	1.5	11	58
	OWB1A6*	6	1.0/1.5	9	32/47
	OWB1A8	8	1.0/1.5	6	21 / 32
	OWB1A10*	10	1.0/1.5	5	18 /26
	OWB1A12	12	1.0/1.5	3.5	12 /18
FB-SB-1316 & FB-SBR-1316	FB-SB-1324	8	1.0	14	49
	FB-SB-1325	8	1.5	14	74
	FB-SB-1326	12	1.0	8.5	30
	FB-SB-1327*	12	1.5	8.5	45
	FB-SB-1328	16	1.0	6	21
	FB-SB-1329	16	1.5	6	32
	FB-SB-1330	20	1.0	4	14
	FB-SB-1331*	20	1.5	4	21
	FB-SB-1332	24	1.0	3.5	12
	FB-SB-1333	24	1.5	3.5	18
	FB-SB-1334	14	1.0	7	25
	FB-SB-1335	14	.5	7	37
	FB-SB-1336	Preparative 1 sample / 1 marker			

FB-SB-2025	FB-SB-2534	8	1.0	22.5	79
	FB-SB-2535	8	1.5	22.5	118
	FB-SB-2536	12	1.0	14.5	51
	FB-SB-2537	12	1.5	14.5	76
	FB-SB-2538	16	1.0	10.5	37
	FB-SB-2539*	16	1.5	10.5	55
	FB-SB-2540	20	1.0	8	28
	FB-SB-2541	20	1.5	8	42
	FB-SB-2542	24	1.0	6.5	23
	FB-SB-2543*	24	1.5	6.5	34
	FB-SB-2544	28	1.0	5	18
	FB-SB-2545	28	1.5	5	26
	FB-SB-2546	32	1.0	4	14
	FB-SB-2547	32	1.5	4	21
	FB-SB-2548	36	1.0	3.5	12
	FB-SB-2549	36*	1.5	3.5	18
	FB-SB-2550	21 (1X)	1.0	7	25
	FB-SB-2551	21 (1X)	1.5	7	37
	FB-SB-2552	42 (2X)	1.0	2.5	9
	FB-SB-2553	42 (2X)	1.5	2.5	13
FB-SB-2554	Preparative 1 sample / 1 marker	1.5	194/5	1000/26	

FB-SB-2318	09 528 164D	25 (1X)	1.0	7.5	22
	09 531 102	25 (1X)	1.5	7.5	30
	09 528 127	50 (2X)	1.0	3	9
	09 531 103*	50 (2X)	1.5	3	15

Section 7
Optional Equipment

FISHER SCIENTIFIC ELECTROPHORESIS PRODUCTS WARRANTY USA

The Warranty Period starts two weeks from the date your equipment is shipped from our facility. This allows shipping time so the warranty will go into effect at approximately the same time your equipment is delivered. The warranty protection extends to any subsequent owner.

During the first thirty-six (36) months, component parts proven to be non-conforming in material or workmanship will be replaced at Fisher Scientific's expense, including labor. Installation, calibration and certification is not covered by this warranty agreement. The Technical Services Department must be contacted for warranty determination and direction prior to performance of any replacements. Expendable items, glass, filters and gaskets are excluded from this warranty.

Replacement of component parts or equipment under this warranty shall not extend the warranty to either the equipment or to the component part beyond the original warranty period. The Technical Services Department must give prior approval for return of any component or equipment. At Fisher Scientific's option, all non-conforming parts must be returned to Fisher Scientific postage paid and replacement parts are shipped FOB destination.

THIS WARRANTY IS EXCLUSIVE AND IN LIEU OF ALL OTHER WARRANTIES, WHETHER WRITTEN, ORAL, OR IMPLIED. NO WARRANTIES OF MERCHANTABILITY OR FITNESS FOR A PARTICULAR PURPOSE SHALL APPLY. Fisher Scientific shall not be liable for any indirect or consequential damages including, without limitation, damages to lost profits or loss of products.

Your local Fisher Scientific Sales Office is ready to help with comprehensive site preparation information before your equipment arrives. Printed instruction manuals carefully detail equipment installation, operation and preventive maintenance.

If equipment service is required, please call your Technical Services Department at 1-800-438-4851 (USA and Canada). We're ready to answer your questions on equipment warranty, operation, maintenance, service, and special applications. Outside the USA, contract your local distributor for warranty information.



Rev. 0 10/17

FISHER SCIENTIFIC ELECTROPHORESIS PRODUCTS WARRANTY INTERNATIONAL

The Warranty Period starts two months from the date your equipment is shipped from our facility. This allows shipping time so the warranty will go into effect at approximately the same time your equipment is delivered. The warranty protection extends to any subsequent owner.

During the first thirty six (36) months, component parts proven to be non-conforming in material or workmanship will be replaced at Fisher Scientific's expense, excepting labor. Installation, calibration and certification is not covered by this warranty agreement. The Technical Services Department must be contacted for warranty determination and direction prior to performance of any replacements. Expendable items, glass, filters and gaskets are excluded from this warranty.

Replacement of component parts or equipment under this warranty shall not extend the warranty to either the equipment or to the component part beyond the original warranty period. The Technical Services Department must give prior approval for return of any component or equipment. At Fisher scientific's option, all non-conforming parts must be returned to Fisher Scientific postage paid and replacement parts are shipped FOB destination.

THIS WARRANTY IS EXCLUSIVE AND IN LIEU OF ALL OTHER WARRANTIES, WHETHER WRITTEN, ORAL, OR IMPLIED. NO WARRANTIES OF MERCHANTABILITY OR FITNESS FOR A PARTICULAR PURPOSE SHALL APPLY. Fisher Scientific shall not be liable for any indirect or consequential damages including, without limitation, damages to lost profits or loss of products.

Your local Fisher Scientific Sales Office is ready to help with comprehensive site preparation information before your equipment arrives. Printed instruction manuals carefully detail equipment installation, operation and preventive maintenance.

If equipment service is required, please call your Technical Services Department at 1-800-438-4851 (USA or Canada). We're ready to answer your questions on equipment warranty, operation, maintenance, service, and special applications. Outside the USA, contract your local distributor for warranty information.



Rev. 0 10/17

© 2020 Thermo Fisher Scientific Inc. All rights reserved.
Trademarks used are owned as indicated at fishersci.com/trademarks.

In the United States:

For customer service, call 1-800-766-7000
To fax an order, use 1-800-926-1166
To order online: fishersci.com

