

Thermo Scientific LH-4000W

Instruction Manual

50134636-b • 07 / 2020

WEEE Conformity

This product is subject to the regulations of the EU Waste Electrical & Electronic Equipment (WEEE) Directive 2012/19/EU. It is marked by the following symbol:

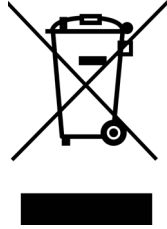

Table of Contents

	Preface	iii
	Scope of Supply	iii
	Precautions	iii
Chapter 1	Rotor Data	1-1
	Technical Data.....	1-2
Chapter 2	Accessories	2-1
	Round Bucket 75006477	2-2
	Double Rectangular Bucket DoubleSpin 75006478	2-3
Chapter 3	Rotor Installation	3-1
	Rotor Installation	3-2
	Removing the Rotor	3-2
Chapter 4	Rotor Loading	4-1
	Before a Run	4-2
	Proper Loading	4-2
	Improper Loading	4-3
	Maximum Loading	4-3
	Cycle Counter	4-4
Chapter 5	Aerosol-tight Applications	5-1
	Basic Principles	5-2
	Closing aerosol-tight	5-2
	Fill Level	5-3
	Checking the Aerosol-Tightness	5-3
Chapter 6	Maintenance and Care	6-1
	Cleaning Intervals	6-2
	Cleaning	6-2
	Disinfection	6-3
	Decontamination	6-4
	Autoclaving	6-5
	Service of Thermo Fisher Scientific	6-5
	RCF-Values	A-1
	Chemical Compatibility Chart	B-1

Preface

Before starting to use the rotor, read through this instruction manual carefully and follow the instructions.

The information contained in this instruction manual is the property of Thermo Fisher Scientific; it is forbidden to copy or pass on this information without explicit approval.

Failure to follow the instructions and safety information in this instruction manual will result in the expiration of the sellers warranty.

Scope of Supply

Article Number		Quantity	Check
75006476	LH-4000W with Bucket	1	<input type="checkbox"/>
76003500	Grease for rubber seal	1	<input type="checkbox"/>
75003786	Bolt grease	1	<input type="checkbox"/>
50134706	CD with manual	1	<input type="checkbox"/>

If any parts are missing, please contact your nearest Thermo Fisher Scientific representative.

Precautions



This symbol refers to general hazards.

WARNING means that injuries or material damage or contamination could occur.

CAUTION means that material damage could occur.



This symbol refers to biological hazards.

Observe the information contained in the instruction manual to keep yourself and your environment safe.

In order to ensure safe operation of the LH-4000W rotor, the following general safety regulations must be followed:

- Do not remove the magnet at the rotor bottom.
- Do not use rotors which show any signs of corrosion and/or cracks.
- Use only with rotors which have been loaded properly.
- Never overload the rotor.
- Operate the rotor always with the lid closed.
- Use only accessories which have been approved by Thermo Fisher Scientific. Exceptions to this rule are commercially available glass or plastic centrifuge tubes, provided they have been approved for the speed or the RCF value of the rotor.
- Please observe the safety instructions.



Please pay particular attention to the following aspects:

- Rotor installation: Check that the rotor is locked properly into place before operating the centrifuge.
- Always balance the samples.

Maximum sample density at maximum speed: $1.2 \frac{g}{cm^3}$

Rotor Data

Contents

- “Technical Data” on [page 1-2](#)

Technical Data

Table 1-1. 230 V, 50 / 60 Hz Round Bucket 75006477

Centrifuge	Cryofuge 5500i	Cryofuge 5500i	Multifuge 4KR
Catalog Number	75004471	75004479	75004461
Weight of empty Rotor [kg]	18.4	18.4	18.4
Max. Cycle Number	30000	30000	30000
Maximum permissible Load [g]	4 x 1400	4 x 1400	4 x 1400
Maximum Speed n_{max} [rpm]	4400	4400	4400
Maximum RCF-Value at n_{max}	5346	5346	5346
Radius max. / min. [cm]	24.7 / 8.8	24.7 / 8.8	24.7 / 8.8
Acceleration / Braking Time [s]	95 / 85	95 / 85	95 / 85
Sample Heating at n_{max} [°C] referred to Ambient Temperature of 23-25 °C, Run Time 60 Minutes	1	1	1
Max. Speed n_{max} [rpm] at 4 °C	4400	4400	4400
Aerosol-tight*	yes (with cap 75006421)	yes (with cap 75006421)	yes (with cap 75006421)
Permissible temperature range autoclavable °C	121	121	121

*tested by TÜV Product Service GmbH - Hamburg

Table 1-2. 230 V, 50 / 60 Hz Double Rectangular Bucket DoubleSpin™ 2 x 250 ml 75006478

Centrifuge	Cryofuge 5500i	Cryofuge 5500i	Multifuge 4KR
Catalog Number	75004471	75004479	75004461
Weight of empty Rotor [kg]	18.4	18.4	18.4
Max. Cycle Number	20000	20000	20000
Maximum permissible Load [g]	4 x 1500	4 x 1500	4 x 1500
Maximum Speed n_{max} [rpm]	4400	4400	4400
Maximum RCF-Value at n_{max}	4654	4654	4654
Radius max. / min. [cm]	21.5 / 11.5	21.5 / 11.5	21.5 / 11.5
Acceleration / Braking Time [s]	95 / 85	95 / 85	95 / 85
Sample Heating at n_{max} [°C] referred to Ambient Temperature of 23-25 °C, Run Time 60 Minutes	1	1	1
Max. Speed n_{max} [rpm] at 4 °C	4400	4400	4400
Aerosol-tight*	yes (with cap 75006479)	yes (with cap 75006479)	yes (with cap 75006479)
Permissible temperature range autoclavable °C	121	121	121

*tested by TÜV Product Service GmbH - Hamburg

Table 1-3. 230 V, 50 / 60 Hz Double Rectangular Bucket 75006436

Centrifuge	Cryofuge 5500i	Cryofuge 5500i	Multifuge 4KR
Catalog Number	75004471	75004479	75004461
Weight of empty Rotor [kg]	17.9	17.9	17.9
Maximum Number of Cycles at Maximum Speed	12000	12000	12000
Maximum permissible Load [g]	4 x 1900	4 x 1900	4 x 1900
Maximum Speed n_{\max} [rpm]	4400	4400	4400
Maximum RCF-Value at n_{\max}	5476	5476	5476
Radius max. / min. [cm]	25.3 / 11.0	25.3 / 11.0	25.3 / 11.0
Acceleration / Braking Time [s]	110 / 90	110 / 90	110 / 90
Sample Heating at n_{\max} [°C] referred to Ambient Temperature of 23-25 °C, Run Time 60 Minutes	1	1	1
Max. Speed n_{\max} [rpm] at 4 °C	4400	4400	4400
Aerosol-tight	no	no	no
Autoclavable	no	no	no

Table 1-4. 200 V, 50 Hz Round Bucket 75006477

Centrifuge	Cryofuge 5500i
Catalog Number	75004479
Weight of empty Rotor [kg]	18.4
Max. Cycle Number	30000
Maximum permissible Load [g]	4 x 1400
Maximum Speed n_{\max} [rpm]	4400
Maximum RCF-Value at n_{\max}	5346
Radius max. / min. [cm]	24.7 / 8.8
Acceleration / Braking Time [s]	95 / 85
Sample Heating at n_{\max} [°C] referred to Ambient Temperature of 23-25 °C, Run Time 60 Minutes	4
Max. Speed n_{\max} [rpm] at 4 °C	4400
Aerosol-tight*	yes (with cap 75006421)
Permissible temperature range autoclavable °C	121

*tested by TÜV Product Service GmbH - Hamburg

1 Rotor Data

Technical Data

Table 1-5. 200 V Double Rectangular Bucket DoubleSpin™ 2 x 250 ml 75006478

Centrifuge	Cryofuge 5500i
Catalog Number	75004479
Weight of empty Rotor [kg]	18.4
Max. Cycle Number	20000
Maximum permissible Load [g]	4 x 1500
Maximum Speed n_{max} [rpm]	4400
Maximum RCF-Value at n_{max}	4654
Radius max. / min. [cm]	21.5 / 11.5
Acceleration / Braking Time [s]	95 / 85
Sample Heating at n_{max} [°C] referred to Ambient Temperature of 23-25 °C, Run Time 60 Minutes	4
Max. Speed n_{max} [rpm] at 4 °C	4400
Aerosol-tight*	yes (with cap 75006479)
Permissible temperature range autoclavable °C	121

* tested by TÜV Product Service GmbH - Hamburg

Table 1-6. 200 V, 50 Hz Double Rectangular Bucket 75006436

Centrifuge	Cryofuge 5500i
Catalog Number	75004479
Weight of empty Rotor [kg]	17.9
Maximum Number of Cycles at Maximum Speed	12000
Maximum permissible Load [g]	4 x 1900
Maximum Speed n_{max} [rpm]	4400
Maximum RCF-Value at n_{max}	5476
Radius max. / min. [cm]	25.3 / 11.0
Acceleration / Braking Time [s]	110 / 90
Sample Heating at n_{max} [°C] referred to Ambient Temperature of 23-25 °C, Run Time 60 Minutes	4
Max. Speed n_{max} [rpm] at 4 °C	4400
Aerosol-tight	no
Autoclavable	no

Table 1-7. 120 V, 60 Hz Round Bucket 75006477

Centrifuge	Cryofuge 5500i
Catalog Number	75004475
Weight of empty Rotor [kg]	18.4
Max. Cycle Number	30000
Maximum permissible Load [g]	4 x 1400
Maximum Speed n_{max} [rpm]	4400
Maximum RCF-Value at n_{max}	5346
Radius max. / min. [cm]	24.7 / 8.8
Acceleration / Braking Time [s]	95 / 85
Sample Heating at n_{max} [°C] referred to Ambient Temperature of 23-25 °C, Run Time 60 Minutes	1
Max. Speed n_{max} [rpm] at 4 °C	4400
Aerosol-tight*	yes (with cap 75006421)
Permissible temperature range autoclavable °C	121

*tested by TÜV Product Service GmbH - Hamburg

Table 1-8. 120 V, 60 Hz Double Rectangular Bucket DoubleSpin™ 2 x 250 ml 75006478

Centrifuge	Cryofuge 5500i
Catalog Number	75004475
Weight of empty Rotor [kg]	18.4
Max. Cycle Number	20000
Maximum permissible Load [g]	4 x 1500
Maximum Speed n_{max} [rpm]	4400
Maximum RCF-Value at n_{max}	4654
Radius max. / min. [cm]	21.5 / 11.5
Acceleration / Braking Time [s]	95 / 85
Sample Heating at n_{max} [°C] referred to Ambient Temperature of 23-25 °C, Run Time 60 Minutes	1
Max. Speed n_{max} [rpm] at 4 °C	4400
Aerosol-tight*	yes (with cap 75006479)
Permissible temperature range autoclavable °C	121

*tested by TÜV Product Service GmbH - Hamburg

1 Rotor Data

Technical Data

Table 1-9. 120 V, 60 Hz Double Rectangular Bucket 75006436

Centrifuge	Cryofuge 5500i
Catalog Number	75004475
Weight of empty Rotor [kg]	17.9
Maximum Number of Cycles at Maximum Speed	12000
Maximum permissible Load [g]	4 x 1900
Maximum Speed n_{\max} [rpm]	4400
Maximum RCF-Value at n_{\max}	5476
Radius max. / min. [cm]	25.3 / 11.0
Acceleration / Braking Time [s]	110 / 90
Sample Heating at n_{\max} [°C] referred to Ambient Temperature of 23-25 °C, Run Time 60 Minutes	1
Max. Speed n_{\max} [rpm] at 4 °C	4400
Aerosol-tight	no
Autoclavable	no

Table 1-10. 230 V, 50 / 60 Hz Round Bucket 75006477

Centrifuge	Sorvall RC-4	Sorvall RC-4
Catalog Number	75004473	75004481
Weight of empty Rotor [kg]	18.4	18.4
Max. Cycle Number	30000	30000
Maximum permissible Load [g]	4 x 1400	4 x 1400
Maximum Speed n_{max} [rpm]	4400	4400
Maximum RCF-Value at n_{max}	5346	5346
Radius max. / min. [cm]	24.7 / 8.8	24.7 / 8.8
Acceleration / Braking Time [s]	95 / 85	95 / 85
Sample Heating at n_{max} [°C] referred to Ambient Temperature of 23-25 °C, Run Time 60 Minutes	1	1
Max. Speed n_{max} [rpm] at 4 °C	4400	4400
Aerosol-tight*	yes (with cap 75006421)	yes (with cap 75006421)
Permissible temperature range autoclavable °C	121	121

*tested by TÜV Product Service GmbH - Hamburg

Table 1-11. 230 V, 50 / 60 Hz Double Rectangular Bucket DoubleSpin™ 2 x 250 ml 75006478

Centrifuge	Sorvall RC-4	Sorvall RC-4
Catalog Number	75004473	75004481
Weight of empty Rotor [kg]	18.4	18.4
Max. Cycle Number	20000	20000
Maximum permissible Load [g]	4 x 1500	4 x 1500
Maximum Speed n_{max} [rpm]	4400	4400
Maximum RCF-Value at n_{max}	4654	4654
Radius max. / min. [cm]	21.5 / 11.5	21.5 / 11.5
Acceleration / Braking Time [s]	95 / 85	95 / 85
Sample Heating at n_{max} [°C] referred to Ambient Temperature of 23-25 °C, Run Time 60 Minutes	1	1
Max. Speed n_{max} [rpm] at 4 °C	4400	4400
Aerosol-tight*	yes (with cap 75006479)	yes (with cap 75006479)
Permissible temperature range autoclavable °C	121	121

*tested by TÜV Product Service GmbH - Hamburg

1 Rotor Data

Technical Data

Table 1-12. 230 V, 50 / 60 Hz Double Rectangular Bucket 75006436

Centrifuge	Sorvall RC-4	Sorvall RC-4
Catalog Number	75004473	75004481
Weight of empty Rotor [kg]	17.9	17.9
Maximum Number of Cycles at Maximum Speed	12000	12000
Maximum permissible Load [g]	4 x 1900	4 x 1900
Maximum Speed n_{\max} [rpm]	4400	4400
Maximum RCF-Value at n_{\max}	5476	5476
Radius max. / min. [cm]	25.3 / 11.0	25.3 / 11.0
Acceleration / Braking Time [s]	110 / 90	110 / 90
Sample Heating at n_{\max} [°C] referred to Ambient Temperature of 23-25 °C, Run Time 60 Minutes	1	1
Max. Speed n_{\max} [rpm] at 4 °C	4400	4400
Aerosol-tight	no	no
Autoclavable	no	no

Table 1-13. 200 V, 50 Hz Round Bucket 75006477

Centrifuge	Sorvall RC-4
Catalog Number	75004481
Weight of empty Rotor [kg]	18.4
Max. Cycle Number	30000
Maximum permissible Load [g]	4 x 1400
Maximum Speed n_{\max} [rpm]	4400
Maximum RCF-Value at n_{\max}	5346
Radius max. / min. [cm]	24.7 / 8.8
Acceleration / Braking Time [s]	95 / 85
Sample Heating at n_{\max} [°C] referred to Ambient Temperature of 23-25 °C, Run Time 60 Minutes	4
Max. Speed n_{\max} [rpm] at 4 °C	4400
Aerosol-tight*	yes (with cap 75006421)
Permissible temperature range autoclavable °C	121

* tested by TÜV Product Service GmbH - Hamburg

Table 1-14. 200 V, 50 Hz Double Rectangular Bucket DoubleSpin™ 2 x 250 ml 75006478

Centrifuge	Sorvall RC-4
Catalog Number	75004481
Weight of empty Rotor [kg]	18.4
Max. Cycle Number	20000
Maximum permissible Load [g]	4 x 1500
Maximum Speed n_{max} [rpm]	4400
Maximum RCF-Value at n_{max}	4654
Radius max. / min. [cm]	21.5 / 11.5
Acceleration / Braking Time [s]	95 / 85
Sample Heating at n_{max} [°C] referred to Ambient Temperature of 23-25 °C, Run Time 60 Minutes	4
Max. Speed n_{max} [rpm] at 4 °C	4400
Aerosol-tight*	yes (with cap 75006479)
Permissible temperature range autoclavable °C	121

*tested by TÜV Product Service GmbH - Hamburg

Table 1-15. 200 V, 50 Hz Double Rectangular Bucket 75006436

Centrifuge	Sorvall RC-4
Catalog Number	75004481
Weight of empty Rotor [kg]	17.9
Maximum Number of Cycles at Maximum Speed	12000
Maximum permissible Load [g]	4 x 1900
Maximum Speed n_{max} [rpm]	4400
Maximum RCF-Value at n_{max}	5476
Radius max. / min. [cm]	25.3 / 11.0
Acceleration / Braking Time [s]	110 / 90
Sample Heating at n_{max} [°C] referred to Ambient Temperature of 23-25 °C, Run Time 60 Minutes	4
Max. Speed n_{max} [rpm] at 4 °C	4400
Aerosol-tight	no
Autoclavable	no

1 Rotor Data

Technical Data

Table 1-16. 120 V, 50 / 60 Hz Round Bucket 75006477

Centrifuge	Sorvall RC-4
Catalog Number	75004477
Weight of empty Rotor [kg]	18.4
Max. Cycle Number	30000
Maximum permissible Load [g]	4 x 1400
Maximum Speed n_{max} [rpm]	4400
Maximum RCF-Value at n_{max}	5346
Radius max. / min. [cm]	24.7 / 8.8
Acceleration / Braking Time [s]	95 / 85
Sample Heating at n_{max} [°C] referred to Ambient Temperature of 23-25 °C, Run Time 60 Minutes	1
Max. Speed n_{max} [rpm] at 4 °C	4400
Aerosol-tight*	yes (with cap 75006421)
Permissible temperature range autoclavable °C	121

*tested by TÜV Product Service GmbH - Hamburg

Table 1-17. 120 V, 50 Hz Double Rectangular Bucket DoubleSpin™ 2 x 250 ml 75006478

Centrifuge	Sorvall RC-4
Catalog Number	75004477
Weight of empty Rotor [kg]	18.4
Max. Cycle Number	20000
Maximum permissible Load [g]	4 x 1500
Maximum Speed n_{max} [rpm]	4400
Maximum RCF-Value at n_{max}	4654
Radius max. / min. [cm]	21.5 / 11.5
Acceleration / Braking Time [s]	95 / 85
Sample Heating at n_{max} [°C] referred to Ambient Temperature of 23-25 °C, Run Time 60 Minutes	1
Max. Speed n_{max} [rpm] at 4 °C	4400
Aerosol-tight*	yes (with cap 75006479)
Permissible temperature range autoclavable °C	121

*tested by TÜV Product Service GmbH - Hamburg

Table 1-18. 120 V, 50 / 60 Hz Double Rectangular Bucket 75006436

Centrifuge	Sorvall RC-4
Catalog Number	75004477
Weight of empty Rotor [kg]	14.4
Maximum Number of Cycles at Maximum Speed	12000
Maximum permissible Load [g]	4 x 1400
Maximum Speed n_{\max} [rpm]	4400
Maximum RCF-Value at n_{\max}	5346
Radius max. / min. [cm]	24.7 / 8.8
Acceleration / Braking Time [s]	85 / 85
Sample Heating at n_{\max} [°C] referred to Ambient Temperature of 23-25 °C, Run Time 60 Minutes	10
Max. Speed n_{\max} [rpm] at 4 °C	4100
Aerosol-tight	no
Autoclavable	no

Accessories

Contents

- “Rotor data” on page 2-2
- “Accessories” on page 2-2

Round Bucket 75006477



CAUTION Close all sample containers before placing them in the bucket.

Table 2-1. Adapters and Accessories for Round Bucket 75006477

Centri-Lab® Adapter Type C	Max. Dimensions x Length* / [mm]	Cap [mm]	Tubes per rotor	Color	Article Number
48 x 1.5 / 2 ml Mikroliter tubes	11.5 x 50	13.0	192	black	75008132
35 x 7 ml DIN	12.8 x 177	14.0	140	yellow	75008133
19 x 7 ml blood sampling	13.5 x 177	18.5	76	light grey	75008134
19 x 15 ml DIN	17.0 x 177	18.5	76	red	75008135
17 x 15 ml blood sampling	17.0 x 177	20	68	olive brown	75008137
12 x 14 / 15 ml with flange	18.3 x 177	21.5	48	brown	75006494
7 x 25 ml DIN	25.0 x 177	31	28	orange	75008138
7 x 45 / 50 ml flat and round bottom	29.5 x 177	31	28	blue	75006493
4 x 50 ml DIN	34.5 x 177	39	16	green	75008140
5 x 50 ml conical	29.5 x 177	35.5	20	light green	75006533
2 x 100 ml DIN	45.0 x 177	47.5	8	light blue	75008142
1 x 150 ml DIN / 180 ml bottle	56.6 x 132 / 128		4	white	75006498
1 x 175-225 ml conical** / 250 ml bottle	62 x 177	75	4	nature	75008144
1 x 250 ml Bottle	59 x 190		4	nature	75006649
1 x 250 ml Corning® tube, conical	61.5 x 190		4	nature	75008147
1 x 500 ml Nalge® tube, conical	70 x 190		4	nature	75008145
1 x 500 ml Corning® tube, conical	96 x 190		4	nature	75006438
Bottle 1000 ml (Nominal volume)	100 x 190				75006613
Aerosol-tight caps	with seals and lubricants (2 pieces)				75006421
Plastic insert "XL"	for 400-500 ml blood bag system (2 pieces)				75006496
Plastic insert "M"	for small volume special blood bank applications (2 pieces)				75006485
Tare plates	caoutchouc 2 x 35 and 65 g each				75005759
Tare weights for plastic insert 75006485	1 set of 4 weights, 6 g and 15 g each				75007645

*Max. Dimensions with aerosol-tight cap

** An additional pad obtainable from tube manufacturer is necessary.

Double Rectangular Bucket DoubleSpin 75006478

Centri-Lab® Adapter Type D	Max. Dimensions x Length* / [mm]	Cap [mm]	Tubes per rotor	Color	Article Number
56 x 1.5 / 2 ml Mikroliter tubes	11 x 50	13.0	448	black	75006452
28 x 7 ml DIN	12.8 x 120 / 151**	14.0	224	yellow	75006453
20 x 7 ml blood sampling	14.0 x 118 / 150	17.5	160	light grey	75006454
16 x 15 ml DIN / blood sampling	17.0 x 120 / 149	19.0	128	red	75006455
9 x 15 ml conical / US-Urine	16.5 x 122 / 153	24.0	72	olive brown	75006456
9 x 14 / 15 ml with flange	18.3 x 122 / 147	25.0	72	brown	75006492
6 x 25 ml DIN	25.5 x 127 / 149	28.0	48	orange	75006457
4 x 25 / 50 ml universal container	25.5 x 132 / 145	32.0	32	blue green	75006459
4 x 45 / 50 ml flat and round bottom	29.5 x 125 / 145	35.0	32	blue	75006491
3 x 50 ml DIN	34.5 x 127 / 148	38.0	24	green	75006460
4 x 50 ml conical	29.5 x 129 / 149	35.5	32	light green	75006461
1 x 100 ml DIN	45.0 x 138	66.0	8	light blue	75006462
1 x 150 ml DIN / 180 ml bottle	56.6 x 147	66.0	8	grey blue	75006463
1 x 50 ml conical*** / 250 ml bottle	62.0 x 140 / 145	63.0	8	black	76006465
24 x 15 ml conical / US-Urine	16.5 x 120 / 147	23	96	nature	75006468
Plate holder for micro test plates.	Basic area 127 x 85; max. height of charge 110 mm				75006486
Aerosol-tight caps	with seals and lubricants (2 pieces)				75006479

*Max. Dimensions with aerosol-tight cap

**The maximum tube length depends on the position in the adapter. In the corners only shorter tubes can be used.

*** An additional pad obtainable from tube manufacturer is necessary.

Double Rectangular Bucket DoubleSpin 75006436

Accessory for Blood Bag Centrifugation		Article Number
Plastic insert "M"	Set of 2	76007667
Plastic insert "L"	Set of 2	76007647
Plastic insert "XL"	Set of 2	76007657
Plastic insert "XXL"	Set of 2	76007677
Tare weight	Tare range 208-1700 g	75007668
Tare weights for plastic insert 75007647	1 set of weights, 6 g and 15 g each	75007645
Tare weight	Caoutchouc 2 x 35 and 65 g each	75005759

Rotor Installation

Contents

- “Rotor Installation” on page 3-2
- “Removing the Rotor” on page 3-2

Rotor Installation

Use only rotors with approved accessories.



CAUTION Unapproved or incorrectly combined accessories can cause serious damage to the centrifuge.

Proceed as follows:

1. Open the lid of the centrifuge and if necessary, remove any dust, foreign objects or residue from the chamber.
Thread and O-ring must be clean and undamaged.
2. Hold the rotor over the centrifuge spindle.
3. Let the rotor slide slowly down the centrifuge spindle.



CAUTION Do not force the rotor onto the centrifuge spindle.

4. Thread the fastening tool into the centrifuge spindle clockwise. Hold the rotor with the other hand into position.
5. Check if the rotor is properly installed by lifting it slightly on the handle.



WARNING Check for any damage to the rotor: Damaged rotors must not be used. Keep the centrifuge spindle area of the rotor clear of objects.



CAUTION Check that the rotor is properly locked on the centrifuge spindle before each use by pulling it at its handle.

6. If available close the rotor with the rotor lid.



Be sure to check all sealings before starting any aerosol-tight applications.

Removing the Rotor

To remove the rotor, proceed as follows:

1. Open the centrifuge door.
2. Thread the fastening tool in the centrifuge spindle counterclockwise. Hold the rotor with the other hand into position.
3. At the same time, pull the rotor directly upwards with both hands and remove it from the centrifuge spindle. Make sure not to tilt the rotor while doing this.

Rotor Loading

Contents

- “Before a Run” on page 4-2
- “Proper Loading” on page 4-2
- “Improper Loading” on page 4-3
- “Maximum Loading” on page 4-3
- “Cycle Counter” on page 4-4

Before a Run

1. Please read and observe the safety instructions contained in this operating instruction and in the instructions for use for centrifuge and rotor.
2. Check the rotor and all accessory parts for damages such as cracks, scratches or traces of corrosion.
3. Check the rotor chamber, the centrifuge spindle and the fixation of the rotor for damages.
4. Check the suitability of the used materials using the chemical compatibility chart on [page B-1](#).
5. Make sure the tubes or bottles do not touch the bucket lid.
6. Close all sample containers before placing them in the bucket.
7. Check the rotor bolts and apply grease 75003786 before using for the first time.
8. Check that each bucket or micro plate carrier can swing freely by moving it carefully with your hand. Weigh the bucket content (adapter and tube). Make sure you do not exceed the maximum compartment load.



CAUTION Always be sure to use buckets of the same weight class.

Proper Loading

To ensure safe operation of the centrifuge, the rotor must be evenly loaded at all times.

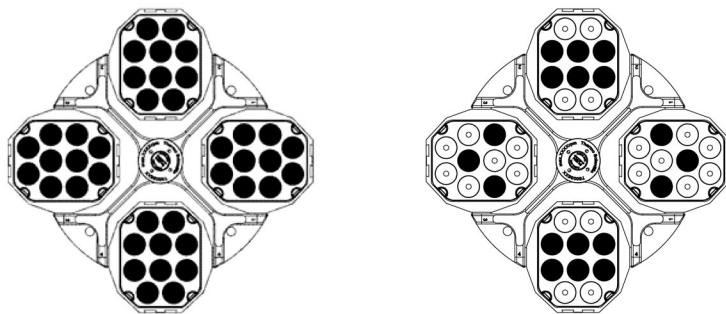

Improper Loading

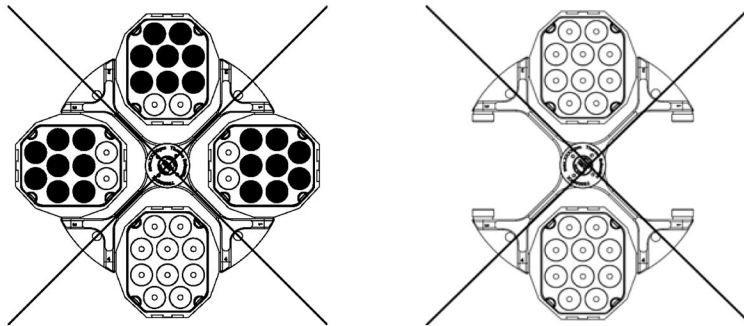

Maximum Loading

The rotor can run at high speeds. The rotor design has sufficient reserve stability even when spinning at top speed.

The safety system of the centrifuge requires that you do not overload the rotor.

There are two options available for centrifuging samples whose weight, including adapter, exceeds the maximum permissible load:

- Reduce the fill level.
- Reduce the speed.

Use the table or the formula:

Actual Load	maximum speed
600	6000
620	5902
640	5809
660	5721
680	5636
700	5555
720	5477
740	5403
760	5331
780	5262
800	5196
820	5132
840	5071
860	5012

4 Rotor Loading

Cycle Counter

Actual Load	maximum speed
880	4954
900	4899

Calculate the maximum speed with this formula and set the centrifuge at the calculated maximum speed:

$$n_{\text{per}} = n_{\text{max}} \sqrt{\frac{\text{maximum load}}{\text{actual load}}}$$

n_{per} = permissible speed

n_{max} = maximum speed

Cycle Counter

The lifetime of rotors and buckets is dependent on the amount of mechanical load. Do not exceed the number of cycles recommended for rotors and buckets.

The maximum number of cycles is given in the rotor table in the rotor specification section.

The maximum number of cycles for buckets is marked on the buckets themselves.



WARNING Replace the rotor when the specified number of cycles is reached. Due to the mechanical load a rotor can break and thus damage the centrifuge. Replace the buckets when the specified number of cycles is reached.

Service life examples

Usage profile	Maximum service life at 30,000 cycles
frequent use 30 runs / day 220 days / year	4.5 years
average use 10 runs / day 220 days / year	13.6 years

Usage profile	Maximum service life at 20,000 cycles
frequent use 30 runs / day 220 days / year	3 years
average use 10 runs / day 220 days / year	9 years

Aerosol-tight Applications

Contents

- “Basic Principles” on page 5-2
- “Closing aerosol-tight” on page 5-2
- “Fill Level” on page 5-3
- “Checking the Aerosol-Tightness” on page 5-3

Basic Principles



CAUTION Aerosol-tight rotors and tubes may only be opened in an approved safety workbench when centrifuging dangerous samples. Mind the maximum permissible load.



CAUTION Be sure to check all sealings before starting any aerosol-tight applications.

- Check that the sample containers are well suited for the desired centrifugation process.

Closing aerosol-tight

Rectangular Bucket 75006478

Grease the seals if necessary, before closing the bucket. Use lubricant 76003500.

Flap both levers upwards.

The cap can be placed easily on the bucket.

Close the bucket aerosol-tight by flapping both levers down until you can hear them locking into place.

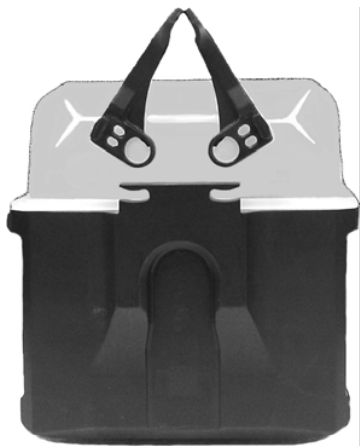

Figure 5-1. Rectangular Bucket with Cap



CAUTION If the levers are not flapped down properly can damage the bucket during centrifugation. The bucket is not closed aerosol-tight if the levers are not in their locking position. Never lift the bucket on the levers.

Round Bucket 75006477

After greasing the seal turn the cap until it fits slightly on the bucket.

To achieve a uniform pressure onto the seal, turn the cap another 1½ grip areas (some 15°). Use the markings on the bucket for orientation.



Fill Level

The tubes are only to be filled to a level which ensures that the sample is unable to reach the top of the tube during centrifugation. Therefore, fill the tube only 2/3 of the rated level.

Checking the Aerosol-Tightness

The aerosol tightness testing of the buckets depends on the microbiological test process in accordance with the EN 61010-2-020 Appendix AA.

Whether or not a bucket is aerosol-tight depends primarily on proper handling.

Check as needed to make sure your bucket is aerosol-tight.

The careful inspection of the seals and seal surfaces for signs of wear and damage such as cracks, scratches and embrittlement is extremely important.

Aerosol-tight applications are not possible if the lids are open.

Aerosol-tightness requires the correct operation when filling the sample vessels and closing the bucket cap.

Quick Test



CAUTION This quick test is not suited for validating the aerosol tightness of your bucket. Check the seals and sealing surfaces of the bucket cap thoroughly.

- Lubricate all seals lightly.
Always use the special grease 76003500 when lubricating the seals.



CAUTION Prior to each use, the seals in the bucket are to be inspected in order to assure that they are correctly seated and are not worn or damaged. Lubricate all seals lightly. Damaged seals must be replaced immediately. When loading the rotor, ensure that the rotor lid closes securely. Damaged or clouded rotor caps must be replaced immediately.

Maintenance and Care

Contents

- “Cleaning Intervals” on page 6-2
- “Cleaning” on page 6-2
- “Disinfection” on page 6-3
- “Decontamination” on page 6-4
- “Autoclaving” on page 6-5
- “Service of Thermo Fisher Scientific” on page 6-5

Cleaning Intervals

For the sake of personal, environmental, and material protection, it is your duty to clean and if necessary, disinfect the centrifuge on a regular basis.

Maintenance	Recommended interval
Clean rotor	daily or when polluted
Accessories	daily or when polluted



CAUTION Refrain from using any other cleaning or decontamination procedure than those recommended here, if you are not entirely sure that the intended procedure is safe for the equipment.
Use only approved cleansers.
If in doubt, contact Thermo Fisher Scientific.

Cleaning

Clean rotor and accessories as follows:

- Use warm water with a neutral solvent.
- Never use caustic cleaning agents such as soap suds, phosphoric acid, bleaching solutions or scrubbing powder.
- Rinse the cavities out thoroughly.
- Use a soft brush without metal bristles to remove stubborn residue.
- Afterwards rinse with distilled water.
- Place the rotors on a plastic grate with their cavities pointing down.
- If drying boxes are used, the temperature must never exceed 50 °C, since higher temperatures could damage the material and shorten the lifetime of the parts.
- Use only disinfectants with a pH of 6-8.
- Dry aluminum parts off with a soft cloth.



CAUTION Before using any cleaning or decontamination methods except those recommended by the manufacturer, users should check with the manufacturer that the proposed method will not damage the equipment.

Clean centrifuge and accessories as follows:

1. Open the centrifuge.
2. Turn off the centrifuge.
3. Pull out the power supply plug.

4. Remove the buckets from the rotor.
5. Remove the centrifuge tubes and adapters and dispose of them or disinfect them.
6. Release the rotor.
7. Grasp the rotor with both hands and lift it vertically off the centrifuge spindle.
8. Use a neutral cleaning agent with a pH value between 6 and 8 for cleaning.
9. Dry all of the rotors and accessories after cleaning with a cloth or in a warm air cabinet at a maximum temperature of 50 °C.
 - After cleaning, treat the entire surface of aluminum parts with corrosion protection oil (70009824). Also treat the cavities with oil.
 - Treat the bolts of the swing out rotor with bolt grease (75003786).



CAUTION When cleaning, do not allow liquids, especially organic solvents, to get on the drive shaft or the bearings of the centrifuge. Organic solvents break down the grease in the motor bearing. The drive shaft could freeze up.

After some applications there might be ice in the rotor chamber. Let the ice melt and drain it off. Clean the rotor chamber as described above.

Disinfection

Disinfect rotor and centrifuge immediately whenever infectious material has spilled during centrifugation.



WARNING Infectious material can get into the centrifuge when a tube breaks or as a result of spills. Keep in mind the risk of infection when touching the rotor and take all necessary precautions. In case of contamination, make sure that others are not put at risk. Decontaminate the affected parts immediately. Take other precautions if need be.

The rotor should be treated preferably with a neutral disinfectant.



CAUTION Before using any cleaning or decontamination methods except those recommended by the manufacturer, users should check with the manufacturer that the proposed method will not damage the equipment. Observe the safety precautions and handling instructions for the cleaning agents used.

Contact the Service Department of Thermo Fisher Scientific for questions regarding the use of other disinfectants.

Disinfect the rotor and accessories as follows:

1. Open the centrifuge.
2. Turn off the centrifuge.
3. Pull out the power supply plug.

4. Remove the buckets from the rotor.
5. Remove the centrifuge tubes and adapters from the bucket and disinfect them.
6. Release the rotor.
7. Grasp the rotor with both hands and lift it vertically off the centrifuge spindle.
8. Treat the rotor and accessories according to the instructions for the disinfectant (spray or soak in solution). Adhere strictly to the given application times.
9. Be sure the disinfectant can drain off the buckets.
10. Rinse the rotor and accessories thoroughly with water.
11. Dispose of the disinfectant according to the applicable guidelines.
12. Dry all of the rotors and accessories after cleaning with a cloth or in a warm air cabinet at a maximum temperature of 50 °C.
13. After cleaning, treat the entire surface of aluminum parts with corrosion protection oil (70009824). Also treat the cavities with oil.
14. Treat the bolts with bolt grease (75003786).

Decontamination

Decontaminate rotor and centrifuge immediately whenever radioactive material has spilled during centrifugation.



WARNING Radioactive material can get into the centrifuge when a tube breaks or as a result of spills. Keep in mind the risk of infection when touching the rotor and take all necessary precautions.

In case of contamination, make sure that others are not put at risk.
Decontaminate the affected parts immediately.
Take other precautions if need be.



CAUTION Before using any cleaning or decontamination methods except those recommended by the manufacturer, users should check with the manufacturer that the proposed method will not damage the equipment.

For general radioactive decontamination use a solution of equal parts of 70 % ethanol, 10 % SDS and water.

1. Open the centrifuge.
2. Turn off the centrifuge.
3. Pull out the power supply plug.
4. Remove the buckets from the rotor.
5. Remove the centrifuge tubes and adapters from the bucket and decontaminate them.
6. Release the rotor.
7. Grasp the rotor with both hands and lift it vertically off the centrifuge spindle.

8. Rinse the rotor first with ethanol and then with deionized water.
 - Adhere strictly to the given application times.
9. Be sure the decontamination solution can drain off the bucket.
10. Rinse the rotor and accessories thoroughly with water.
11. Dispose of the decontamination solution according to the applicable guidelines.
12. Dry all of the rotors and accessories after cleaning with a cloth or in a warm air cabinet at a maximum temperature of 50 °C.
13. After cleaning, treat the entire surface of aluminum parts with corrosion protection oil (70009824). Also treat the cavities with oil.
14. Treat the bolt of the swing out rotor with bolt grease (75003786).

Autoclaving

1. Before autoclaving clean rotor and buckets as described above.
2. Place the rotor on a flat surface.
 - Rotors and adapter can be autoclaved at 121 °C.
 - The maximum permissible autoclave cycle is 20 minutes at 121 °C.

Note No chemical additives are permitted in the steam.



CAUTION Never exceed the permitted temperature and duration when autoclaving. If the rotor shows signs of corrosion or wear, it must be replaced.

Autoclaving of Polypropylene Bottle 75006613

Note The bottle can be autoclaved at 121 °C, 1 bar overpressure for 20 minutes.

1. Remove the seal from the cap and wrap it in aluminum foil before autoclaving.
2. Screw the cap slightly onto the bottle before autoclaving.
3. After autoclaving place the seal back in the cap in a sterile work bench.

Note If you use the bottle without seal sample liquid can escape. Reduce the volume if necessary.

Service of Thermo Fisher Scientific

Thermo Fisher Scientific recommends having the centrifuge and accessories serviced once a year by an authorized service technician. The service technician checks the following:

- the electrical equipment;
- the suitability of the set-up site;

6 Maintenance and Care

Service of Thermo Fisher Scientific

- the lid lock and the safety system;
- the rotor;
- the fixation of the rotor and the drive shaft.

Thermo Fisher Scientific offers inspection and service contracts for this work. Any necessary repairs are performed for free during the warranty period and afterwards for a charge.

This is only valid if the centrifuge has only been maintained by a Thermo Fisher Scientific service technician.

RCF-Values

Table A-1. Round Buckets 75006477

rpm	R _{min}	R _{max}	RCF R _{min}	RCF R _{max}
300	8.8	24.7	9	25
400	8.8	24.7	16	44
500	8.8	24.7	25	69
600	8.8	24.7	35	99
700	8.8	24.7	48	135
800	8.8	24.7	63	177
900	8.8	24.7	80	224
1000	8.8	24.7	98	276
1100	8.8	24.7	119	334
1200	8.8	24.7	142	398
1300	8.8	24.7	166	467
1400	8.8	24.7	193	541
1500	8.8	24.7	221	621
1600	8.8	24.7	252	707
1700	8.8	24.7	284	798
1800	8.8	24.7	319	895
1900	8.8	24.7	355	997
2000	8.8	24.7	394	1105
2100	8.8	24.7	434	1218
2200	8.8	24.7	476	1337
2300	8.8	24.7	520	1461
2400	8.8	24.7	567	1591
2500	8.8	24.7	615	1726
2600	8.8	24.7	665	1867
2700	8.8	24.7	717	2013
2800	8.8	24.7	771	2165
2900	8.8	24.7	827	2322

Table A-1. Round Buckets 75006477

rpm	R_{\min}	R_{\max}	RCF R_{\min}	RCF R_{\max}
3000	8.8	24.7	885	2485
3100	8.8	24.7	945	2654
3200	8.8	24.7	1007	2828
3300	8.8	24.7	1071	3007
3400	8.8	24.7	1137	3192
3500	8.8	24.7	1205	3383
3600	8.8	24.7	1275	3579
3700	8.8	24.7	1347	3780
3800	8.8	24.7	1421	3988
3900	8.8	24.7	1496	4200
4000	8.8	24.7	1574	4418
4100	8.8	24.7	1654	4642
4200	8.8	24.7	1735	4871
4300	8.8	24.7	1819	5106
4400	8.8	24.7	1905	5346

Table A-2. Double Rectangular Bucket 75006478

rpm	R_{\min}	R_{\max}	RCF R_{\min}	RCF R_{\max}
300	11.5	21.5	12	22
400	11.5	21.5	21	38
500	11.5	21.5	32	60
600	11.5	21.5	46	87
700	11.5	21.5	63	118
800	11.5	21.5	82	154
900	11.5	21.5	104	195
1000	11.5	21.5	129	240
1100	11.5	21.5	156	291
1200	11.5	21.5	185	346
1300	11.5	21.5	217	406
1400	11.5	21.5	252	471
1500	11.5	21.5	289	541
1600	11.5	21.5	329	615
1700	11.5	21.5	372	695
1800	11.5	21.5	417	779
1900	11.5	21.5	464	868

Table A-2. Double Rectangular Bucket 75006478

rpm	R_{\min}	R_{\max}	RCF R_{\min}	RCF R_{\max}
2000	11.5	21.5	514	961
2100	11.5	21.5	567	1060
2200	11.5	21.5	622	1163
2300	11.5	21.5	680	1272
2400	11.5	21.5	741	1385
2500	11.5	21.5	804	1502
2600	11.5	21.5	869	1625
2700	11.5	21.5	937	1752
2800	11.5	21.5	1008	1885
2900	11.5	21.5	1081	2022
3000	11.5	21.5	1157	2163
3100	11.5	21.5	1236	2310
3200	11.5	21.5	1317	2461
3300	11.5	21.5	1400	2618
3400	11.5	21.5	1486	2779
3500	11.5	21.5	1575	2945
3600	11.5	21.5	1666	3115
3700	11.5	21.5	1760	3291
3800	11.5	21.5	1857	3471
3900	11.5	21.5	1956	3656
4000	11.5	21.5	2057	3846
4100	11.5	21.5	2161	4041
4200	11.5	21.5	2268	4240
4300	11.5	21.5	2377	4444
4400	11.5	21.5	2489	4654

Table A-3. Double Rectangular Bucket 75006436

rpm	R_{\min}	R_{\max}	RCF R_{\min}	RCF R_{\max}
300	11	25.3	11	25
400	11	25.3	20	45
500	11	25.3	31	71
600	11	25.3	44	102
700	11	25.3	60	139
800	11	25.3	79	181
900	11	25.3	100	229

Table A-3. Double Rectangular Bucket 75006436

rpm	R _{min}	R _{max}	RCF R _{min}	RCF R _{max}
1000	11	25.3	123	283
1100	11	25.3	149	342
1200	11	25.3	177	407
1300	11	25.3	208	478
1400	11	25.3	241	554
1500	11	25.3	277	636
1600	11	25.3	315	724
1700	11	25.3	355	817
1800	11	25.3	398	916
1900	11	25.3	444	1021
2000	11	25.3	492	1131
2100	11	25.3	542	1247
2200	11	25.3	595	1369
2300	11	25.3	651	1496
2400	11	25.3	708	1629
2500	11	25.3	769	1768
2600	11	25.3	831	1912
2700	11	25.3	897	2062
2800	11	25.3	964	2218
2900	11	25.3	1034	2379
3000	11	25.3	1107	2546
3100	11	25.3	1182	2718
3200	11	25.3	1259	2896
3300	11	25.3	1339	3080
3400	11	25.3	1422	3270
3500	11	25.3	1507	3465
3600	11	25.3	1594	3666
3700	11	25.3	1684	3872
3800	11	25.3	1776	4084
3900	11	25.3	1871	4302
4000	11	25.3	1968	4526
4100	11	25.3	2067	4755
4200	11	25.3	2169	4990
4300	11	25.3	2274	5230
4400	11	25.3	2381	5476

Chemical Compatibility Chart

CHEMICAL	MATERIAL	ALUMINIUM	ANODIC COATING for ALUMINIUM	BUNA N	CELLULOSE ACETATE BUTYRATE	POLYURETHANE ROTOR PAINT	COMPOSITE Carbon Fiber/Epoxy	DELRIN	ETHYLENE PROPYLENE	GLASS	NEOPRENE	NORYL	NYLON	PET ¹ , POLYCLEAR	POLYALLOMER	POLYCARBONATE	POLYESTER, GLASS THERMOSET	POLYETHERIMIDE	POLYRTHYLENE	POLYPROPYLENE	POLYSULFONE	POLYVINYL CHLORIDE	RULON A, TEFLON	SILICONE RUBBER	STAINLESS STEEL	TITANIUM	TYGON	VITON
2-mercaptoethanol	S	S	U	-	S	M	S	-	S	U	S	S	U	S	S	-	S	S	S	S	U	S	S	S	S	S	S	S
Acetaldehyde	S	-	U	U	-	-	-	M	-	U	-	-	-	M	U	U	U	M	M	-	M	S	U	-	S	-	U	
Acetone	M	S	U	U	S	U	M	S	S	U	U	S	U	S	U	U	U	S	S	U	U	S	M	M	S	U	U	
Acetonitrile	S	S	U	-	S	M	S	-	S	S	U	S	U	M	U	U	-	S	M	U	U	S	S	S	S	U	U	
Alconox	U	U	S	-	S	S	S	-	S	S	S	S	S	S	M	S	S	S	S	S	S	S	S	S	S	S	U	
Allyl Alcohol	-	-	-	U	-	-	S	-	-	-	-	S	-	S	S	M	S	S	S	-	M	S	-	-	S	-	-	
Aluminum Chloride	U	U	S	S	S	S	U	S	S	S	S	M	S	S	S	S	-	S	S	S	S	S	M	U	U	S	S	
Formic Acid (100 %)	-	S	M	U	-	-	U	-	-	-	-	U	-	S	M	U	U	S	S	-	U	S	-	U	S	-	U	
Ammonium Acetate	S	S	U	-	S	S	S	-	S	S	S	S	S	S	S	U	-	S	S	S	S	S	S	S	S	S	S	S
Ammonium Carbonate	M	S	U	S	S	S	S	S	S	S	S	S	S	S	U	U	-	S	S	S	S	S	S	M	S	S	S	
Ammonium Hydroxide (10 %)	U	U	S	U	S	S	M	S	S	S	S	S	-	S	U	M	S	S	S	S	S	S	S	S	S	M	S	
Ammonium Hydroxide (28 %)	U	U	S	U	S	U	M	S	S	S	S	S	U	S	U	M	S	S	S	S	S	S	S	S	S	M	S	
Ammonium Hydroxide (conc.)	U	U	U	U	S	U	M	S	-	S	-	S	U	S	U	U	S	S	S	-	M	S	S	S	S	-	U	
Ammonium Phosphate	U	-	S	-	S	S	S	S	S	S	S	S	-	S	S	M	-	S	S	S	S	S	S	M	S	S	S	
Ammonium Sulfate	U	M	S	-	S	S	U	S	S	S	S	S	S	S	S	S	-	S	S	S	S	S	U	S	S	U		
Amyl Alcohol	S	-	M	U	-	-	S	S	-	M	-	S	-	M	S	S	S	S	M	-	-	-	U	-	S	-	M	
Aniline	S	S	U	U	S	U	S	M	S	U	U	U	U	U	U	U	-	S	M	U	U	S	S	S	S	U	S	
Sodium Hydroxide (<1 %)	U	-	M	S	S	S	-	-	S	M	S	S	-	S	M	M	S	S	S	S	S	S	M	S	S	-	U	
Sodium Hydroxide (10 %)	U	-	M	U	-	-	U	-	M	M	S	S	U	S	U	U	S	S	S	S	S	S	M	S	S	-	U	
Barium Salts	M	U	S	-	S	S	S	S	S	S	S	S	S	S	S	M	-	S	S	S	S	S	M	S	S	S	S	
Benzene	S	S	U	U	S	U	M	U	S	U	U	S	U	U	U	M	U	M	U	U	U	S	U	U	S	U	S	
Benzyl Alcohol	S	-	U	U	-	-	M	M	-	M	-	S	U	U	U	U	U	U	U	-	M	S	M	-	S	-	S	
Boric Acid	U	S	S	M	S	S	U	S	S	S	S	S	S	S	S	S	U	S	S	S	S	S	S	S	S	S	S	
Cesium Acetate	M	-	S	-	S	S	S	-	S	S	S	S	-	S	S	-	-	S	S	S	S	S	S	M	S	S	S	

B Chemical Compatibility Chart

CHEMICAL	MATERIAL																										
	ALUMINIUM	ANODIC COATING for ALUMINIUM	BUNA N	CELLULOSE ACETATE BUTYRATE	POLYURETHANE ROTOR PAINT	COMPOSITE Carbon Fiber/Epoxy	DELRIN	ETHYLENE PROPYLENE	GLASS	NEOPRENE	NORYL	NYLON	PET ¹ , POLYCLEAR	POLYALLOMER	POLYCARBONATE	POLYESTER, GLASS THERMOSET	POLYETHERIMIDE	POLYETHYLENE	POLYPROPYLENE	POLYSULFONE	POLYVINYL CHLORIDE	RULON A, TERLON	SILICONE RUBBER	STAINLESS STEEL	TITANIUM	TYGON	VITON
Cesium Bromide	M	S	S	-	S	S	S	-	S	S	S	S	S	S	S	-	-	S	S	S	S	S	S	M	S	S	S
Cesium Chloride	M	S	S	U	S	S	S	-	S	S	S	S	S	S	S	-	-	S	S	S	S	S	S	M	S	S	S
Cesium Formate	M	S	S	-	S	S	S	-	S	S	S	S	S	S	S	-	-	S	S	S	S	S	S	M	S	S	S
Cesium Iodide	M	S	S	-	S	S	S	-	S	S	S	S	S	S	S	-	-	S	S	S	S	S	S	M	S	S	S
Cesium Sulfate	M	S	S	-	S	S	S	-	S	S	S	S	S	S	S	-	-	S	S	S	S	S	S	M	S	S	S
Chloroform	U	U	U	U	S	S	M	U	S	U	U	M	U	M	U	U	U	M	M	U	U	S	U	U	U	M	S
Chromic Acid (10 %)	U	-	U	U	S	U	U	-	S	S	S	U	S	S	M	U	M	S	S	U	M	S	M	U	S	S	S
Chromic Acid (50 %)	U	-	U	U	-	U	U	-	-	-	S	U	U	S	M	U	M	S	S	U	M	S	-	U	M	-	S
Cresol Mixture	S	S	U	-	-	-	S	-	S	U	U	U	U	U	U	-	-	U	U	-	U	S	S	S	S	U	S
Cyclohexane	S	S	S	-	S	S	S	U	S	U	S	S	U	U	U	M	S	M	U	M	M	S	U	M	M	U	S
Deoxycholate	S	S	S	-	S	S	S	-	S	S	S	S	S	S	S	-	-	S	S	S	S	S	S	S	S	S	S
Distilled Water	S	S	S	S	S	S	S	S	S	S	S	S	S	S	S	S	S	S	S	S	S	S	S	S	S	S	S
Dextran	M	S	S	S	S	S	S	-	S	S	S	S	S	S	S	S	S	S	S	S	S	S	S	M	S	S	S
Diethyl Ether	S	S	U	U	S	S	S	U	S	U	U	S	U	U	U	U	U	U	U	U	U	S	S	S	S	M	U
Diethyl Ketone	S	-	U	U	-	-	M	-	S	U	-	S	-	M	U	U	U	M	M	-	U	S	-	-	S	U	U
Diethylpyrocarbonate	S	S	U	-	S	S	S	-	S	S	U	S	U	S	U	-	-	S	S	S	M	S	S	S	S	S	S
Dimethylsulfoxide	S	S	U	U	S	S	S	-	S	U	S	S	U	S	U	U	-	S	S	U	U	S	S	S	S	U	U
Dioxane	M	S	U	U	S	S	M	M	S	U	U	S	U	M	U	U	-	M	M	M	U	S	S	S	S	U	U
Ferric Chloride	U	U	S	-	-	-	M	S	-	M	-	S	-	S	-	-	-	S	S	-	-	-	M	U	S	-	S
Acetic Acid (Glacial)	S	S	U	U	S	S	U	M	S	U	S	U	U	U	U	U	M	S	U	M	U	S	U	U	S	-	U
Acetic Acid (5 %)	S	S	M	S	S	S	M	S	S	S	S	S	M	S	S	S	S	S	S	M	S	S	M	S	S	M	M
Acetic Acid (60 %)	S	S	U	U	S	S	U	-	S	M	S	U	U	M	U	S	M	S	M	S	M	S	M	U	S	M	U
Ethyl Acetate	M	M	U	U	S	S	M	M	S	S	U	S	U	M	U	U	-	S	S	U	U	S	M	M	S	U	U
Ethyl Alcohol (50 %)	S	S	S	S	S	S	M	S	S	S	S	S	U	S	U	S	S	S	S	S	S	S	S	M	S	M	U
Ethyl Alcohol (95 %)	S	S	S	U	S	S	M	S	S	S	S	S	U	S	U	-	S	S	S	M	S	S	S	U	S	M	U
Ethylene Dichloride	S	-	U	U	-	-	S	M	-	U	U	S	U	U	U	U	U	U	U	-	U	S	U	-	S	-	S
Ethylene Glycol	S	S	S	S	S	S	S	S	S	S	S	S	-	S	U	S	S	S	S	S	S	S	S	M	S	M	S
Ethylene Oxide Vapor	S	-	U	-	-	U	-	-	S	U	-	S	-	S	M	-	-	S	S	S	U	S	U	S	S	S	U
Ficoll-Hypaque	M	S	S	-	S	S	S	-	S	S	S	S	-	S	S	-	S	S	S	S	S	S	S	M	S	S	S
Hydrofluoric Acid (10 %)	U	U	U	M	-	-	U	-	-	U	U	S	-	S	M	U	S	S	S	S	M	S	U	U	U	-	-
Hydrofluoric Acid (50 %)	U	U	U	U	-	-	U	-	-	U	U	U	U	S	U	U	U	S	S	M	M	S	U	U	U	-	M
Hydrochloric Acid (conc.)	U	U	U	U	-	U	U	M	-	U	M	U	U	M	U	U	U	-	S	-	U	S	U	U	U	-	-

B Chemical Compatibility Chart

CHEMICAL	MATERIAL																											
	ALUMINIUM	ANODIC COATING for ALUMINIUM	BUNA N	CELLULOSE ACETATE BUTYRATE	POLYURETHANE ROTOR PAINT	COMPOSITE Carbon Fiber/Epoxy	DELRIN	ETHYLENE PROPYLENE	GLASS	NEOPRENE	NORYL	NYLON	PET ¹ , POLYCLEAR	POLYALLOMER	POLYCARBONATE	POLYESTER, GLASS THERMOSET	POLYETHERIMIDE	POLYETHYLENE	POLYPROPYLENE	POLYSULFONE	POLYVINYL CHLORIDE	RUJON A, TEFLON	SILICONE RUBBER	STAINLESS STEEL	TITANIUM	TYGON	VITON	
Formaldehyde (40 %)	M	M	M	S	S	S	S	M	S	S	S	S	M	S	S	S	U	S	S	M	S	S	S	M	S	M	U	
Glutaraldehyde	S	S	S	S	-	-	S	-	S	S	S	S	S	S	S	-	-	S	S	S	-	-	S	S	S	-	-	
Glycerol	M	S	S	-	S	S	S	S	S	S	S	S	S	S	S	S	-	S	S	S	S	S	S	S	S	S	S	
Guanidine Hydrochloride	U	U	S	-	S	S	S	-	S	S	S	S	S	S	S	-	-	S	S	S	S	S	S	U	S	S	S	
Haemo-Sol	S	S	S	-	-	-	S	-	S	S	S	S	S	S	S	-	-	S	S	S	S	S	S	S	S	S	S	
Hexane	S	S	S	-	S	S	S	-	S	S	U	S	U	M	U	S	S	U	S	S	M	S	U	S	S	U	S	
Isobutyl Alcohol	-	-	M	U	-	-	S	S	-	U	-	S	U	S	S	M	S	S	S	-	S	S	S	-	S	-	S	
Isopropyl Alcohol	M	M	M	U	S	S	S	S	S	U	S	S	U	S	U	M	S	S	S	S	S	S	S	M	M	M	S	
Iodoacetic Acid	S	S	M	-	S	S	S	-	S	M	S	S	M	S	S	-	M	S	S	S	S	S	M	S	S	M	M	
Potassium Bromide	U	S	S	-	S	S	S	-	S	S	S	S	S	S	S	S	S	S	S	-	S	S	S	M	S	S	S	
Potassium Carbonate	M	U	S	S	S	S	S	-	S	S	S	S	S	S	U	S	S	S	S	S	S	S	S	S	S	S	S	
Potassium Chloride	U	S	S	-	S	S	S	S	S	S	S	S	S	S	S	-	S	S	S	S	S	S	S	U	S	S	S	
Potassium Hydroxide (5 %)	U	U	S	S	S	S	M	-	S	S	S	S	-	S	U	S	S	S	S	S	S	S	M	U	M	S	U	
Potassium Hydroxide (conc.)	U	U	M	U	-	-	M	-	M	S	S	-	U	M	U	U	U	S	M	-	M	U	-	U	U	-	U	
Potassium Permanganate	S	S	S	-	S	S	S	-	S	S	S	U	S	S	S	M	-	S	M	S	U	S	S	M	S	U	S	
Calcium Chloride	M	U	S	S	S	S	S	S	S	S	S	S	S	S	M	S	-	S	S	S	S	S	S	M	S	S	S	
Calcium Hypochlorite	M	-	U	-	S	M	M	S	-	M	-	S	-	S	M	S	-	S	S	S	M	S	M	U	S	-	S	
Kerosene	S	S	S	-	S	S	S	U	S	M	U	S	U	M	M	S	-	M	M	M	S	S	U	S	S	U	S	
Sodium Chloride (10 %)	S	-	S	S	S	S	S	S	-	-	-	S	S	S	S	S	-	S	S	S	S	-	S	S	M	-	S	
Sodium Chloride (sat'd)	U	-	S	U	S	S	S	-	-	-	-	S	S	S	S	S	-	S	S	-	S	-	S	S	M	-	S	
Carbon Tetrachloride	U	U	M	S	S	U	M	U	S	U	U	S	U	M	U	S	S	M	M	S	M	M	M	M	U	S	S	
Aqua Regia	U	-	U	U	-	-	U	-	-	-	-	-	U	U	U	U	U	U	U	-	-	-	-	-	-	S	-	M
Solution 555 (20 %)	S	S	S	-	-	-	S	-	S	S	S	S	S	S	S	-	-	S	S	S	-	S	S	S	S	S	S	
Magnesium Chloride	M	S	S	-	S	S	S	S	S	S	S	S	S	S	S	S	S	S	S	S	S	S	S	M	S	S	S	
Mercaptoacetic Acid	U	S	U	-	S	M	S	-	S	M	S	U	U	U	U	-	S	U	U	S	M	S	U	S	S	S	S	
Methyl Alcohol	S	S	S	U	S	S	M	S	S	S	S	S	U	S	U	M	S	S	S	S	S	S	S	M	S	M	U	
Methylene Chloride	U	U	U	U	M	S	S	U	S	U	U	S	U	U	U	U	U	M	U	U	U	U	S	S	M	U	U	
Methyl Ethyl Ketone	S	S	U	U	S	S	M	S	S	U	U	S	U	S	U	U	U	S	S	U	U	S	S	S	S	U	U	
Metrizamide	M	S	S	-	S	S	S	-	S	S	S	S	-	S	S	-	-	S	S	S	S	S	S	M	S	S	S	
Lactic Acid (100 %)	-	-	S	-	-	-	-	-	-	M	S	U	-	S	S	S	M	S	S	-	M	S	M	S	S	-	S	
Lactic Acid (20 %)	-	-	S	S	-	-	-	-	-	M	S	M	-	S	S	S	S	S	S	S	M	S	M	S	S	-	S	
N-Butyl Alcohol	S	-	S	U	-	-	S	-	-	S	M	-	U	S	M	S	S	S	S	M	M	S	M	-	S	-	S	

B Chemical Compatibility Chart

CHEMICAL	MATERIAL																										
	ALUMINIUM	ANODIC COATING for ALUMINIUM	BUNA N	CELLULOSE ACETATE BUTYRATE	POLYURETHANE ROTOR PAINT	COMPOSITE Carbon Fiber/Epoxy	DELRIN	ETHYLENE PROPYLENE	GLASS	NEOPRENE	NORYL	NYLON	PET ¹ , POLYCLEAR	POLYALLOMER	POLYCARBONATE	POLYESTER, GLASS THERMOSET	POLYETHERIMIDE	POLYETHYLENE	POLYPROPYLENE	POLYSULFONE	POLYVINYL CHLORIDE	RULON A, TERLON	SILICONE RUBBER	STAINLESS STEEL	TITANIUM	TYGON	VITON
N-Butyl Phthalate	S	S	U	-	S	S	S	-	S	U	U	S	U	U	U	M	-	U	U	S	U	S	M	M	S	U	S
N, N-Dimethylformamide	S	S	S	U	S	M	S	-	S	S	U	S	U	S	U	U	-	S	S	U	U	S	M	S	S	S	U
Sodium Borate	M	S	S	S	S	S	S	S	S	S	S	U	S	S	S	S	-	S	S	S	S	S	S	M	S	S	S
Sodium Bromide	U	S	S	-	S	S	S	-	S	S	S	S	S	S	S	S	-	S	S	S	S	S	S	M	S	S	S
Sodium Carbonate (2 %)	M	U	S	S	S	S	S	S	S	S	S	S	S	S	U	S	S	S	S	S	S	S	S	S	S	S	S
Sodium Dodecyl Sulfate	S	S	S	-	S	S	S	-	S	S	S	S	S	S	S	-	S	S	S	S	S	S	S	S	S	S	S
Sodium Hypochlorite (5 %)	U	U	M	S	S	M	U	S	S	M	S	S	S	M	S	S	S	S	M	S	S	S	M	U	S	M	S
Sodium Iodide	M	S	S	-	S	S	S	-	S	S	S	S	S	S	S	-	-	S	S	S	S	S	S	M	S	S	S
Sodium Nitrate	S	S	S	-	S	S	S	S	S	S	S	S	S	S	S	S	-	S	S	S	S	S	U	S	S	S	S
Sodium Sulfate	U	S	S	-	S	S	S	S	S	S	S	S	S	S	S	S	S	S	S	S	S	S	S	M	S	S	S
Sodium Sulfide	S	-	S	S	-	-	-	S	-	-	-	S	S	S	U	U	-	-	S	-	-	-	S	S	M	-	S
Sodium Sulfite	S	S	S	-	S	S	S	S	M	S	S	S	S	S	S	M	-	S	S	S	S	S	S	S	S	S	S
Nickel Salts	U	S	S	S	S	S	-	S	S	S	-	-	S	S	S	S	-	S	S	S	S	S	S	M	S	S	S
Oils (Petroleum)	S	S	S	-	-	-	S	U	S	S	S	S	U	U	M	S	M	U	U	S	S	S	U	S	S	S	S
Oils (Other)	S	-	S	-	-	-	S	M	S	S	S	S	U	S	S	S	S	U	S	S	S	S	-	S	S	M	S
Oleic Acid	S	-	U	S	S	S	U	U	S	U	S	S	M	S	S	S	S	S	S	S	S	S	M	U	S	M	M
Oxalic Acid	U	U	M	S	S	S	U	S	S	S	S	U	S	U	S	S	S	S	S	S	S	S	S	U	M	S	S
Perchloric Acid (10 %)	U	-	U	-	S	U	U	-	S	M	M	-	-	M	U	M	S	M	M	-	M	S	U	-	S	-	S
Perchloric Acid (70 %)	U	U	U	-	-	U	U	-	S	U	M	U	U	M	U	U	U	M	M	U	M	S	U	U	S	U	S
Phenol (5 %)	U	S	U	-	S	M	M	-	S	U	M	U	U	S	U	M	S	M	S	U	U	S	U	M	M	M	S
Phenol (50 %)	U	S	U	-	S	U	M	-	S	U	M	U	U	U	U	U	S	U	M	U	U	S	U	U	U	M	S
Phosphoric Acid (10 %)	U	U	M	S	S	S	U	S	S	S	S	U	-	S	S	S	S	S	S	S	S	S	U	M	U	S	S
Phosphoric Acid (conc.)	U	U	M	M	-	-	U	S	-	M	S	U	U	M	M	S	S	S	M	S	M	S	U	M	U	-	S
Physiologic Media (Serum, Urine)	M	S	S	S	-	-	S	-	S	S	S	S	S	S	S	S	S	S	S	S	S	S	S	S	S	S	S
Picric Acid	S	S	U	-	S	M	S	S	S	M	S	U	S	S	S	U	S	S	S	S	U	S	U	M	S	M	S
Pyridine (50 %)	U	S	U	U	S	U	U	-	U	S	S	U	U	M	U	U	-	U	S	M	U	S	S	U	U	U	U
Rubidium Bromide	M	S	S	-	S	S	S	-	S	S	S	S	S	S	S	-	-	S	S	S	S	S	S	M	S	S	S
Rubidium Chloride	M	S	S	-	S	S	S	-	S	S	S	S	S	S	S	-	-	S	S	S	S	S	S	M	S	S	S
Sucrose	M	S	S	-	S	S	S	S	S	S	S	S	S	S	S	S	S	S	S	S	S	S	S	S	S	S	S
Sucrose, Alkaline	M	S	S	-	S	S	S	-	S	S	S	S	S	U	S	S	S	S	S	S	S	S	S	M	S	S	S
Sulfosalicylic Acid	U	U	S	S	S	S	S	-	S	S	S	U	S	S	S	-	S	S	S	-	S	S	U	S	S	S	S
Nitric Acid (10 %)	U	S	U	S	S	U	U	-	S	U	S	U	-	S	S	S	S	S	S	S	S	S	M	S	S	S	S

CHEMICAL	MATERIAL																										
	ALUMINIUM	ANODIC COATING for ALUMINIUM	BUNA N	CELLULOSE ACETATE BUTYRATE	POLYURETHANE ROTOR PAINT	COMPOSITE Carbon Fiber/Epoxy	DELRIN	ETHYLENE PROPYLENE	GLASS	NEOPRENE	NORYL	NYLON	PET ¹ , POLYGLAR	POLYALLOMER	POLYCARBONATE	POLYESTER, GLASS THERMOSET	POLYETHERIMIDE	POLYETHYLENE	POLYPROPYLENE	POLYSULFONE	POLYVINYL CHLORIDE	RUJON A, TEFLON	SILICONE RUBBER	STAINLESS STEEL	TITANIUM	TYGON	VITON
Nitric Acid (50 %)	U	S	U	M	S	U	U	-	S	U	S	U	U	M	M	U	M	M	M	S	S	S	U	S	S	M	S
Nitric Acid (95 %)	U	-	U	U	-	U	U	-	-	U	U	U	U	M	U	U	U	U	M	U	U	S	U	S	S	-	S
Hydrochloric Acid (10 %)	U	U	M	S	S	S	U	-	S	S	S	U	U	S	U	S	S	S	S	S	S	S	S	U	M	S	S
Hydrochloric Acid (50 %)	U	U	U	U	S	U	U	-	S	M	S	U	U	M	U	U	S	S	S	S	M	S	M	U	U	M	M
Sulfuric Acid (10 %)	M	U	U	S	S	U	U	-	S	S	M	U	S	S	S	S	S	S	S	S	S	S	U	U	U	S	S
Sulfuric Acid (50 %)	M	U	U	U	S	U	U	-	S	S	M	U	U	S	U	U	M	S	S	S	S	S	U	U	U	M	S
Sulfuric Acid (conc.)	M	U	U	U	-	U	U	M	-	-	M	U	U	S	U	U	U	M	S	U	M	S	U	U	U	-	S
Stearic Acid	S	-	S	-	-	-	S	M	S	S	S	S	-	S	S	S	S	S	S	S	S	S	M	M	S	S	S
Tetrahydrofuran	S	S	U	U	S	U	U	M	S	U	U	S	U	U	U	-	M	U	U	U	U	S	U	S	S	U	U
Toluene	S	S	U	U	S	S	M	U	S	U	U	S	U	U	U	S	U	M	U	U	U	S	U	S	U	U	M
Trichloroacetic Acid	U	U	U	-	S	S	U	M	S	U	S	U	U	S	M	-	M	S	S	U	U	S	U	U	U	M	U
Trichloroethane	S	-	U	-	-	-	M	U	-	U	-	S	U	U	U	U	U	U	U	U	U	S	U	-	S	-	S
Trichloroethylene	-	-	U	U	-	-	-	U	-	U	-	S	U	U	U	U	U	U	U	U	U	S	U	-	U	-	S
Trisodium Phosphate	-	-	-	S	-	-	M	-	-	-	-	-	-	S	-	-	S	S	S	-	-	S	-	-	S	-	S
Tris Buffer (neutral pH)	U	S	S	S	S	S	S	-	S	S	S	S	S	S	S	S	S	S	S	S	S	S	S	S	S	S	S
Triton X-100	S	S	S	-	S	S	S	-	S	S	S	S	S	S	S	S	S	S	S	S	S	S	S	S	S	S	S
Urea	S	-	U	S	S	S	S	-	-	-	-	S	S	S	M	S	S	S	S	-	S	S	S	M	S	-	S
Hydrogen Peroxide (10 %)	U	U	M	S	S	U	U	-	S	S	S	U	S	S	S	M	U	S	S	S	S	S	S	M	S	U	S
Hydrogen Peroxide (3 %)	S	M	S	S	S	-	S	-	S	S	S	S	S	S	S	S	M	S	S	S	S	S	S	S	S	S	S
Xylene	S	S	U	S	S	S	M	U	S	U	U	U	U	U	U	M	U	M	U	U	U	S	U	M	S	U	S
Zinc Chloride	U	U	S	S	S	S	U	S	S	S	S	S	S	S	S	S	S	S	S	S	S	S	S	U	S	S	S
Zinc Sulfate	U	S	S	-	S	S	S	S	S	S	S	S	S	S	S	S	S	S	S	S	S	S	S	S	S	S	S
Citric Acid (10 %)	M	S	S	M	S	S	M	S	S	S	S	S	S	S	S	S	M	S	S	S	S	S	S	S	S	S	S

¹Polyethyleneterephthalate

Key

- S Satisfactory
- M Moderate attack, may be satisfactory for use in centrifuge depending on length of exposure, speed involved, etc. Suggest testing under actual conditions of use.
- U Unsatisfactory, not recommended.
- Performance unknown; suggest testing, using sample to avoid loss of valuable material.

B Chemical Compatibility Chart

Chemical resistance data is included only as a guide to product use. No organized chemical resistance data exists for materials under the stress of centrifugation. When in doubt we recommend pretesting sample lots.



Thermo Electron LED GmbH
Zweigniederlassung Osterode
Am Kalkberg, 37520 Osterode am Harz
Germany

thermofisher.com/rotors

© 2012-2020 Thermo Fisher Scientific Inc. All rights reserved.

All trademarks are the property of Thermo Fisher Scientific Inc. and its subsidiaries unless otherwise indicated.

Delrin, TEFLON, and Viton are registered trademarks of DuPont. Noryl is a registered trademark of SABIC. POLYCLEAR is a registered trademark of Hongye CO., Ltd. Hypaque is a registered trademark of Amersham Health As. RULON A and Tygon are registered trademarks of Saint-Gobain Performance Plastics. Alconox is a registered trademark of Alconox. Ficoll is a registered trademark of GE Healthcare. Haemo-Sol is a registered trademark of Haemo-Sol. Triton is a registered trademark of Union Carbide Corporation. Valox is a registered trademark of General Electric Co.

Specifications, terms and pricing are subject to change. Not all products are available in all countries. Please consult your local sales representative for details.

Shown pictures within the manual are examples and may differ considering the set parameters and language. Pictures of the user interface within the manual are showing the English version as example.

Australia +61 39757 4300

Austria +43 1 801 40 0

Belgium +32 9 272 54 82

China +800 810 5118, +400 650 5118

France +33 2 2803 2180

Germany national toll free
0800 1 536 376

Germany international +49 6184 90 6000

India toll free +1800 22 8374

India +91 22 6716 2200

Italy +39 02 95059 552

Japan +81 3 5826 1616

Korea +82 2 2023 0600

Netherlands +31 76 579 55 55

New Zealand +64 9 980 6700

Nordic/Baltic/CIS countries
+358 10 329 2200

Russia +7 812 703 42 15, +7 495 739 76 41

Singapore +82 2 3420 8700

Spain/Portugal +34 93 223 09 18

Switzerland +41 44 454 12 12

UK/Ireland +44 870 609 9203

USA/Canada +1 866 984 3766

Other Asian Countries +852 3107 7600

Countries not listed +49 6184 90 6000

en

