

Laboratory & Pharmacy Refrigerators

TSG Series

Installation and Operation

333924H01 • Revision A • 6/13/23



IMPORTANT Read this instruction manual. Failure to follow the instructions in this manual can result in damage to the unit, injury to operating personnel, and poor equipment performance.

CAUTION All internal adjustments and maintenance must be performed by qualified service personnel.

Material in this manual is for informational purposes only. The contents and the product it describes are subject to change without notice. Thermo Fisher Scientific makes no representations or warranties with respect to this manual. In no event shall Thermo be held liable for any damages, direct or incidental, arising from or related to the use of this manual.

© 2023 Thermo Fisher Scientific Inc. All rights reserved.

For your future reference and when contacting the factory, please have the following information readily available. It can be found on the data plate attached to your unit.

Model Number: _____

Serial Number: _____

The following information, if available, is helpful for contacting the factory.

Date Purchased: _____

Purchase order number: _____

Source of Purchase: _____

(manufacturer or specific agent/rep organization)

Contents

Model.....	1
Safety Precautions.....	2
Unpacking.....	4
Packing List	4
General Recommendations	5
Temperature Monitoring	5
Door Management	5
Intended Use.....	5
Initial Loading.....	5
Operating Standards	6
Unit Specifications	6
Installation.....	8
Location	8
Installation Instructions	8
Wiring	9
Shelves.....	11
Baskets	11
Installation Instructions	11
Door Operation	11
Remote Alarm (Optional).....	12
Final Checks	13
Startup	14
Initial Startup.....	14
Product Loading and Unloading Guidelines.....	14

Operation	15
Control Panel	15
Standard display	17
Navigation	17
Screens	19
Programming mode	20
Temperature settings	20
Direct functions	20
Calibration (parameters /cc to /cr)	22
Backup battery.....	22
Temperature monitoring	22
Alarms and Signals	23
Types of alarms.....	23
Alarm table.....	24
Maintenance	26
Cleaning the Cabinet Interior	26
Cleaning the Condenser Filter	26
Cleaning the Condenser	26
Automatic Defrost	26
Gasket Maintenance	27
Alarm Battery Maintenance.....	27
Preparation for Storage.....	27
Probe Recalibration Schedule	27
Troubleshooting.....	28
End of Life Care	30
Warranty	31

Regulatory Compliance	32
Product Safety	32
Hydrocarbon Refrigerants.....	32
Electromagnetic Compatibility	32
Energy Efficiency.....	33

Model

The table below shows the units covered in this operation and installation manual by model number.

Table 1. Applicable Models

Unit	Model (*)
Thermo Scientific - TSG1205G*	A/D/V
Thermo Scientific - TSG1205S*	A/D/V
Thermo Scientific - TSG1205P*	A/D/V
Thermo Scientific - TSG2305G*	A/D/V
Thermo Scientific - TSG2305S*	A/D/V
Thermo Scientific - TSG2305P*	A/D/V
Thermo Scientific - TSG3005G*	A/D/V
Thermo Scientific - TSG3005S*	A/D/V
Thermo Scientific - TSG3005P*	A/D/V
Thermo Scientific - TSG4505G*	A/D/V
Thermo Scientific - TSG5005G*	A/D/V
Thermo Scientific - TSG5005S*	A/D/V
Thermo Scientific - TSG5005P*	A/D/V

Safety Precautions

In this manual, the following symbols and conventions are used:



This symbol when used alone indicates important operating instructions which reduce the risk of injury or poor performance of the unit.



WARNING: This symbol indicates potentially hazardous situations which, if not avoided, could result in serious injury or death.



WARNING: This symbol indicates situations where dangerous voltages exist and potential for electrical shock is present.



WARNING: This symbol indicates potentially hazardous situations, which if not avoided could result in fire.



CAUTION: This symbol, in the context of a CAUTION, indicates a potentially hazardous situation which if not avoided could result in minor to moderate injury or damage to the equipment.



CAUTION: This indicates a situation which may result in property damage.



This symbol indicates surfaces which may become hot during use and may cause a burn if touched with unprotected body parts.



Before installing, using or maintaining this product, please be sure to read the manual and product warning labels carefully. Failure to follow these instructions may cause the product to malfunction, which could result in injury or damage.



This symbol indicates the need for users to consult the instructions for use.



This symbol indicates possible pinch points which may cause personal injury.



This symbol indicates a need to use gloves during the indicated procedures. If performing decontamination procedures, use chemically resistant gloves.



This symbol indicates possible sharp points which may cause skin abrasion.

Below are important safety precautions that apply to this product.



CAUTION: Use this product only in the way described in the product literature and in this manual. Before using it, verify that this product is suitable for its intended use. If the equipment is used in a manner not specified by the manufacturer, the protection provided by the equipment may be impaired.



CAUTION: Do not modify system components, especially the controller. Use OEM exact replacement equipment or parts. Before use, confirm that the product has not been altered in any way.



WARNING: Risk of Shock. Your unit must be properly grounded in conformity with national and local electrical codes. Do not connect the unit to overloaded power sources.



WARNING: Risk of Shock. Disconnect unit from all power sources before cleaning, troubleshooting, or performing other maintenance on the product or its controls.



WARNING: Risk of Fire. This unit is not for storage of flammable materials.



WARNING: Risk of Fire. This unit is charged with hydrocarbon refrigerants. Only qualified service personnel should service this unit.



CAUTION: Unauthorized repair of your refrigerator will invalidate your warranty. Contact Technical Service at 1-800-438-4851 for additional information.



WARNING: Risk of Fire. No equipment that uses an open flame should be placed inside the unit. This will harm the unit, hamper functionality and compromise your safety.



WARNING: Risk of Fire. Do not use any battery powered or externally-powered equipment in the device.



CAUTION: Risk of Abrasion. Hidden sharp edges may be present on drawers. Use appropriate Personal Protective Equipment (such as gloves) while handling the drawers to avoid possible sharp points related injury.

EMC



사용자 안내문 이 기기는 업무용 환경에서 사용할 목적으로 적합성평가를 받은 기기로서 가정용 환경에서 사용하는 경우 전파간섭의 우려가 있습니다.

WARNING: EMC Registration is done on this equipment for business use only. It may cause interference when the product would be used in home.

This equipment has been tested and found to comply with the limits for a Class A digital device. Class A covers devices for usage in all establishments other than domestic and that are not directly connected to a low voltage power supply network, which supplies domestic environment.

This ISM device complies with Canadian ICES-001.

FCC

This equipment has been tested and found to comply with the limits for a Class A digital device, pursuant to part 15 of the FCC Rules. These limits are designed to provide reasonable protection against harmful interference when the equipment is operated in a commercial environment. This equipment generates, uses, and can radiate radio frequency energy and, if not installed and used in accordance with the instruction manual, may cause harmful interference to radio communications. Operation of this equipment in a residential area is likely to cause harmful interference in which case the user will be required to correct the interference at his own expense.

Unpacking

At the time of delivery, be sure to inspect the unit packaging for damage before signing for the shipment. If packaging damage is present, request immediate product inspection and file a claim with the carrier.

Note: Packaging damage does not denote that unit damage exists.

If concealed damage is found (damage that is not apparent until the item has been unpacked), stop further unpacking and save all packing for carrier inspection. Make a written request for inspection to delivering carrier. This must be done within 15 days after delivery. Then file a claim with the carrier.

Do not return goods to the manufacturer without written authorization.

Packing List

Inside the refrigerator cabinet is a bag containing:

- Essential safety instructions, including translated versions
- Certificate of Conformance
- Warranty Card
- Two cabinet door keys

If you have ordered a unit with shelves, the bag will also contain:

- Small bag with shelving clips

If specified on the order, the bag may also include:

- QC temperature graph and test log
- Calibration information

Other items with your unit include:

- Power cord
- Anti-Tip Bracket Kit (See **Installation Instructions** and **Table 3** for applicable models)
- Baskets or Shelves

Manual Label provides link to Installation and Operation Manual for the unit.

Note: To download the complete Installation and Operation Manual for the unit, please visit:

<https://www.thermofisher.com/usermanuals>

General Recommendations

This section includes some general recommendations for your unit.

Temperature Monitoring



IMPORTANT NOTE: We recommend the use of a redundant and independent temperature monitoring system so that the unit can be monitored continuously for performance commensurate with the value of product stored.

Door Management

When the door is open, the high temperature alarm is ignored for 1 minute to avoid false alarms, and the service icon flashes to signal a warning condition. When time Add has elapsed, the following occur:

- The open door alarm (dor) is signaled;
- Compressor and evaporator fan control resumes;
- The light stays on;
- The high temperature alarm is activated.

When closing the door:

- Control resumes, restarting the compressor and evaporator fans if required.
- The light switches off and the high temperature alarm is activated.

Intended Use

The 5°C refrigerator described in this manual are high performance units for professional use. These products are intended for use as cold storage of temperature sensitive materials such as media, reagents, and clinical* and laboratory products. Models denoted as Pharmacy (TSGxx05Px) are additionally intended for pharmaceuticals, vaccines, chemotherapy drugs and other pharmacy-grade products.

Expected users of this equipment include but are not limited to personnel from the following areas: professional and clinical* laboratories Pharma and Biotech facilities, Academic, Industrial, and Government facilities or those trained in

laboratory protocols but in place at your facility. The units are not for use by the general public.

*These products are not considered as medical devices and have not been evaluated for use in environment or applications involving the diagnosis of diseases or other conditions, or in the cure, mitigation, treatment, or prevention of disease in man or other animals.

These devices are not intended for the storage of samples to be re-introduced to the body (Examples: Blood and Blood Components, Tissue, Cells). These devices are not intended for use in classified hazardous locations, nor to be used for the storage of flammable or corrosive inventory.



CAUTION: Storage of unsealed corrosive substances may cause the interior of the unit to corrode.

Initial Loading

Allow the unit to operate at the desired temperature for a minimum of 12 hours before loading.

Load the unit one shelf at a time, starting from bottom to top shelf. After loading each shelf, allow the unit to recover to the desired set point before loading the next shelf. Repeat this process until the unit is fully loaded. Please refer to the section **Shelves** for shelf load ratings.



CAUTION: Failure to follow these procedures or overloading the unit may cause undue stress on the compressors or jeopardize user product safety.

Operating Standards

The units described in this manual are classified for use as stationary equipment in a Pollution Degree 2 and Over voltage Category II environment.

These units are designed to operate under the following environmental conditions:

- Indoor use
- Altitude up to 2000 m (6512 feet).
- Maximum relative humidity 60% for temperatures from 15°C to 27°C (59°F to 80°F), or maximum relative humidity 40% for temperatures from 28°C to 32°C (82°F to 90°F).
- Main supply voltage fluctuations not to drop or exceed by 10% of the nominal voltage.
- Do not connect the unit to a GFCI (Ground Fault Circuit Interrupter) protected outlet as it may be subject to nuisance tripping.
- Do not use extension cords with this unit.

Unit Specifications

The data label is located on the left side on top towards front of the unit.

The specifications of refrigerator like voltage, required wall breaker amperage and power plug are same for all the units.

This plug must be plugged into / supplied with its own individual branch circuit.

Other specifications are listed in the table below.

Table 2. Unit Specifications

Model	Rated Voltage	Rated Current	Frequency / Phase	Power Module Plug	Glass Door Unit Weight Kg (lbs)[†]	Solid Door Unit Weight Kg (lbs)[†]	Exterior Dimensions (D x W x H)
12A	115 V	2.20 A	60 Hz/1	IEC C19	119 (262)	119 (262)	79.0 x 61.9 x 185.4 cm (31.1 x 24.0 x 73.0 in)
12D	208-230 V	1.10 A	60 Hz/1				
12V	208-230 V	1.10 A	50 Hz/1				
23A	115 V	2.20 A	60 Hz/1		141 (311)	141 (311)	96.2 x 71.1 x 199.4 cm (37.9 x 28.0 x 78.5 in)
23D	208-230 V	1.10 A	60 Hz/1				
23V	208-230 V	1.10 A	50 Hz/1				
30A	115 V	2.20 A	60 Hz/1		153 (337)	153 (337)	96.2 x 86.4 x 199.4 cm (37.9 x 34.0 x 78.5 in)
30D	208-230 V	1.10 A	60 Hz/1				
30V	208-230 V	1.10 A	50 Hz/1				
45A	115 V	3.67 A	60 Hz/1		211 (465)	N/A	93.1 x 143.5 x 199.4 cm (36.6 x 56.5 x 78.5 in)
45D	208-230 V	2.10 A	60 Hz/1				
45V	208-230 V	2.10 A	50 Hz/1				
50A	115 V	3.67 A	60 Hz/1		226 (498)	226 (498)	96.2 x 143.5 x 199.4 cm (37.9 x 56.5 x 78.5 in)
50D	208-230 V	2.10 A	60 Hz/1				
50V	208-230 V	2.10 A	50 Hz/1				

† Weights provided are approximate weights for Laboratory Refrigerators with shelves. For TSG1205P* Pharmacy Refrigerators, add 22 Kg (49 lbs). For TSG2305P*, TSG3005P*, and TSG5005P* Pharmacy Refrigerators, add 37 Kg (82 lbs) for each set of 6 drawers.

Installation



WARNING: Risk of Shock. Do not exceed the electrical rating printed on the data plate located on the upper left side of the unit.



CAUTION: Do not move the unit using the drain pan on the back. This could cause damage to the equipment.

Location

Install the unit on a level area free from vibration with a minimum of 6 inches of space on the sides and rear and 12 inches at the top. Do not position the equipment in direct sunlight or near heating diffusers, radiators, or other sources of heat.



WARNING: Risk of Injury. Do not move the unit while loaded. Move by pushing slowly at handle level or lower. Use caution on uneven surfaces.

Installation Instructions

The unit must be level both front to back and side to side when installed. If the unit is out of level, you may need to shim the corners or casters with thin sheets of metal. Be sure to set the brakes for units equipped with casters.



CAUTION: An unlevel unit may result in instability and performance issues for the doors and drawers.



WARNING: The refrigerator must be secured by the anti-tip bracket supplied. Unless properly installed, the refrigerator could tip when shelves/drawers/baskets are loaded. Injury and damage to the equipment and contents may result from the refrigerator tipping.

This refrigerator has been designed to meet all recognized industry tip standards for all normal conditions when anti-tip bracket is installed and properly engaged.

*Check the product data plate to confirm model number.

Anti-tip Bracket Installation instructions are provided for wood and concrete floors. Any other type of construction may require special installation techniques as deemed necessary to provide adequate fastening of the anti-tip bracket to the floor. For installation on floors other than wood and concrete, please contact technical support.

The use of this bracket does not prevent the tipping of the refrigerator when not properly installed.

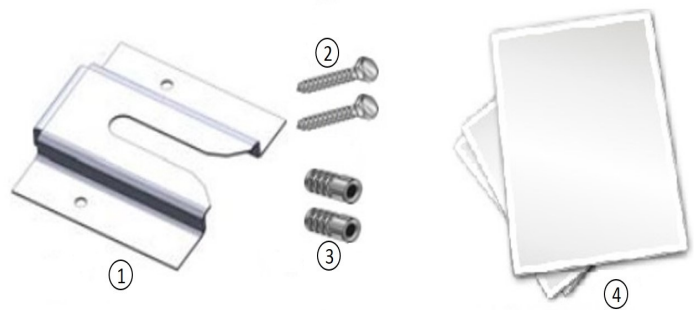

Figure 1. Materials Supplied

Label	Description
1	Bracket
2	Bolts
3	Anchors
4	Instructions and Installation Template

Table 3. Tools Required

Wood Floor	Concrete Floor
Flashlight	
Tape Measure	
1/2" (13 mm) Wrench	
3/4" (19 mm) Wrench	
Drill	Hammer Drill
15/64" (6 mm) Drill Bit	1/2" (13 mm) Masonry Bit

1. Locating the Bracket

- Determine where you want the centerline of the refrigerator to be.
- Place the included template on the floor lined up with the centerline of the refrigerator and keep 6"- 12" between the wall and the back of the unit.
- On the floor, mark the location of Hole #1 and Hole #2 (and Hole #3 and Hole #4 for double door units).

2. Anti-Tip Bracket Installation

Wood Construction

- Drill 15/64" (6 mm) pilot holes in locations marked in step 1.
- Place bracket on floor aligned with holes.
- Use supplied lag bolts to attach bracket to floor.

Concrete Construction

- Drill 1/2" (13 mm) holes in locations marked in step 1 with masonry bit.
- Slide lag screw anchors into holes to be flush with floor surface.
- Place bracket on floor aligned with holes.
- Use supplied lag bolts to attach bracket to floor.

3. Adjusting Bolt in Refrigerator

- Locate 1/2" bolt attached to bottom of cabinet.
- Unscrew 1/2" bolt until there is 1/2" clearance between floor and head of bolt as shown in the **Figure 2**.
- Tighten lock nut against bottom of unit.

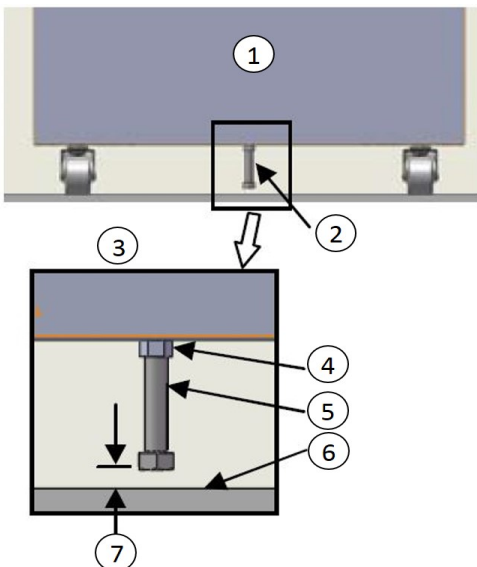

Figure 2. Bolt Location

Label	Description
1	Back of Unit
2	1/2" Bolt Location
3	Detailed View
4	Lock Nut
5	1/2" Bolt
6	Floor
7	1/2" Clearance

4. Refrigerator Positioning

- Line up 1/2" bolt installed in step 3 with anti-tip bracket.
- Roll or slide refrigerator into position until bolt stops against bracket.
- Lock the casters.

5. Checking the Installation

Check to see if the anti-tip bracket is installed properly by shining light under cabinet and confirming bolt in cabinet is secured by bracket on floor.

Wiring

Wiring diagrams are attached on the back of the cabinet.



CAUTION: Connect the equipment to the correct power source. Incorrect voltage can result in severe damage to the equipment.



CAUTION: Risk of Shock. For personal safety and trouble-free operation, this unit must be properly grounded while in use. Failure to ground the equipment may cause personal injury or damage to the equipment. Always conform to the National Electrical Code and local codes. Do not connect the unit to overloaded power lines.



Do not position the unit in a way that impedes access to the disconnecting device or circuit breaker in the back of the unit.



Always connect the unit to a dedicated (separate) circuit. Each unit is equipped with a service cord and plug designed to connect it to a power outlet which delivers the correct voltage. Supply voltage must be within $\pm 10\%$ of the unit rated voltage. If cord becomes damaged, replace with a properly rated power supply cord.

Table 4. Power Cord Specification

Model	Power Cord Specifications
A	3-G 12 AWG, NEMA 5-15P, 15 A/125 V
D	3-G 14 AWG, NEMA 6-15P, 15 A/250 V
V	3-G 1.5 mm ² , CEE 7/7, 16 A/250 V



CAUTION: Risk of Shock. Never cut the grounding prong from the service cord plug. If the prong is removed, the warranty is invalidated.



In an emergency, the power cord is a disconnect device.

Shelves

Single door laboratory refrigerators come standard with 4 full shelves and double door laboratory refrigerators come standard with 8 full shelves.

Maximum shelf capacity is 45 kg (100 lbs).

For safety in shipping, the shelves are packaged and secured inside the cabinet. Insert the shelf support hangers (included inside the unit) into the built-in shelf supports (located on the inside walls of the cabinet interior) at the desired locations. Position the shelves on the flat supports (refer to Figure 5). If you have a Pharmacy model, do not position shelving where it will disrupt the thermal bottle and probe assembly.



Figure 3. Shelf Support Hanger

Baskets

Pharmacy models ship with baskets installed. 12 cubic foot Pharmacy models ship with 5 baskets, 23 and 30 cubic foot Pharmacy models ship with 6 baskets, and 50 cubic foot Pharmacy models ship with 12 baskets.

Baskets are shipped in a factory installed position that promotes uniform spacing between the baskets. The baskets slides are adjustable to higher and lower positions in the cabinet. You can position these slides in the vertical slots which are spaced at one-inch intervals. The baskets must be removed in order to adjust the position of the basket slides.

For TSG1205P, TSG2305P, and TSG5005P, the maximum basket capacity is 27 kg (60 lbs). For TSG3005P, the maximum basket capacity is 36 kg (80 lbs).

Installation Instructions



WARNING: Do not to move this unit while loaded

1. Determine proper locations for shelf clips- the reference number on the pilaster can serve as a guide to ensure all clips are properly located and even.
2. Insert the top of the shelf clip into the desired hole of the pilaster- the retaining tab should be facing upwards.
3. Rotate the shelf clip downwards and insert the bottom tab into the appropriate hole in the pilaster. Note that the clip may need to be squeezed slightly during installation in order to fit.
4. Install shelves onto clips with the product retention bar facing upwards. Be careful not to dislodge clips during shelf installation.
5. Prior to loading the shelf, ensure that the shelf is resting on each of 4 clips and the clips are installed.



CAUTION: Improper shelf clip installation may cause shelf and/or product damage to the unit.



CAUTION: Do not overload the shelves, the unit is designed to utilize all shelves that are supplied in an equally spaced manner.

Door Operation

Laboratory refrigerators have either swinging or sliding doors.



CAUTION: Door seal integrity is critical for unit's performance. Never route anything through the door seal. A loose fitting gasket allows moist air to be drawn into the cabinet, resulting in quicker frost buildup on the evaporator coil, longer running time, poor temperature maintenance, and increased operation cost.



WARNING: Risk of Fire. There are port holes in the walls of the cabinet to help facilitate routing of tubing, independent temperature sensors, and other non-electrical items. The ports are not intended to supply power to devices inside the device. Be sure to seal the holes after routing items to prevent undesired air exchange.

Swinging Doors

The doors on all swinging door units are designed to stay open if opened 90 degrees or more. The door spring tension cannot be adjusted. If the self-closing door does not work properly, make sure the unit is level.



CAUTION: Keep hands and body parts clear of closing doors. The moving parts create a potential pinch point.

Sliding Doors

The doors on the 45 cu.ft. models are self-closing sliding glass doors. If the self-closing mechanism is not working properly, check to make sure that the unit is level.



CAUTION: Keep hands and body parts clear of closing doors. The moving parts create a potential pinch point.

The sliding glass doors can be locked once they are in the closed position using the key provided. To lock these doors:

1. Locate the lock in the middle of the cabinet at the bottom of the doors.
2. Rotate the lock lever clockwise from the upwards to downwards position.
3. Insert and turn the key an additional 180 degrees clockwise.
4. Remove the key and the door is locked.

To unlock the doors, reverse the steps above.

There is a hook in the middle of the cabinet at the top of the doors that can be used to keep the doors open when required.

Remote Alarm (Optional)

All units have factory-installed local alarm contacts that can be used for remote alarm systems.

The maximum distance between a refrigerator and a remote alarm depends on the wire gauge used. Refer to the table below:

Remote alarm terminals are located at the rear of the machine compartment. The three terminals are: COMMON, OPEN ON FAIL (Normally Closed), and CLOSE ON FAIL (Normally Open).

Table 5. Remote Alarm

Wire Gauge	Total Wire Length (feet)	Distance to Alarm 1/2 Wire Length (feet)
20	530	265
18	840	420
16	1330	665
14	2120	1060
12	3370	1685

REMOTE ALARM CONNECTIONS

CONNEXIONS DE L'ALARME À DISTANCE

CONTACT RATING 1 AMP MAX
CLASS 2 CIRCUIT ONLY

VALEUR NOMINALE DE CONTACT DE 1 AMP MAX.
SUR UN CIRCUIT DE CLASSE 2 UNIQUEMENT

WIRE COLOR (FIL DE COULEUR)	FUNCTION (FONCTION)
○ — GREEN (VERT)	COMMON (COMMUNE)
○ — BLACK (NOIR)	OPEN ON FAIL (EN POSITION OUVERTE)
○ — RED (ROUGE)	CLOSE ON FAIL (EN POSITION FERMÉE)

To install the remote alarm, make the following connections:

1. Connect the COMMON terminal on the cabinet switch to the COMMON wire on the alarm.
2. To get an alarm when the switch contacts open, connect the OPEN ON FAIL terminal on the cabinet to the OPEN ON FAIL wire on the alarm.
 - a. To get an alarm when the switch contacts close, connect the CLOSE ON FAIL terminal on the cabinet to the CLOSE ON FAIL wire on the alarm. The COMMON and CLOSE ON FAIL wires must be tied together in this application.
3. Plug the alarm system service cord into an electrical outlet.

The contacts will trip in the event of a power outage, high temperature alarm or low temperature alarm.

Final Checks

Before start up, be sure to complete the following steps:

1. Make sure that the unit is free of all wood or cardboard shipping materials, both inside and outside.
2. Check the positions of the shelves, baskets. If you want to adjust the positions, see instructions in **Shelves, Baskets**.
3. Verify that the unit is connected to a dedicated circuit.

Startup

Initial Startup

To start up the refrigerator, complete the following steps:

1. If you have a Pharmacy model, verify that the sensor probe(s) have been installed in the bottle(s).
2. Connect the AC mains power cord to the mains power inlet connector.
3. Ensure the double pole circuit breaker switch located next to the power inlet is in "OFF" position (i.e. "O" position).
4. Connect AC mains power cord to a wall outlet on a dedicated circuit.
5. Ensure the double pole circuit breaker switch located next to the power inlet is in "ON" position (i.e. "I" position).
6. Unit may alarm due to high temperature at initial startup. Press the "Prg" button to silence this alarm for initial startup. Please see operation section for additional details.
7. Allow the unit to reach operating temperature before loading it with any product. To stabilize the temperature profile, a 24-hour waiting period is recommended.
8. If you have a remote alarm, hook it up at this point (refer to **Remote Alarm (Optional)**).
9. If desired, lock the cabinet door using the key. Place duplicate key copies in a safe place.

All controls should now be fully operational, the alarm active (if enabled), and all visual indicators active.

Product Loading and Unloading Guidelines

When loading your laboratory refrigerator, take care to observe the following guidelines:

- Distribute the load as evenly as possible. Temperature uniformity depends on air circulation, which could be impeded if the internal storage components are overfilled, particularly at the top of the cabinet.
- For critical applications, be sure that the alarm systems are working and active before you load any product.
- Ensure clearance between the top of the cargo and the bottom of the shelf/basket. Lack of clearance may affect

unit performance or impede operation of basket. Keep cargo within the bounds of the shelf/basket.

- For initial product loading and after removing the baskets for cleaning, be sure to load the unit from the bottom basket / Shelf up to ensure the components are seated properly. (Applicable for baskets only.)
- Only open one basket at a time.
- If you have a Pharmacy model, avoid disrupting the thermal bottle(s) when repositioning interior components.
- The floor of the cabinet should not be loaded.
- Never load the unit above the load limit line. This is important to ensure that air can circulate properly and evenly distribute the temperature throughout the interior.

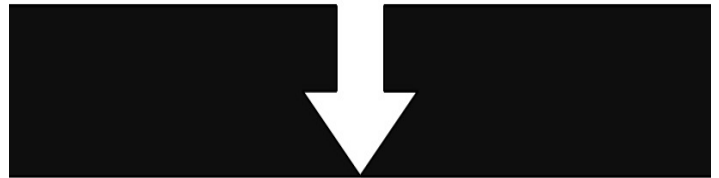

Figure 4. Load Limit Line

Operation

Control Panel

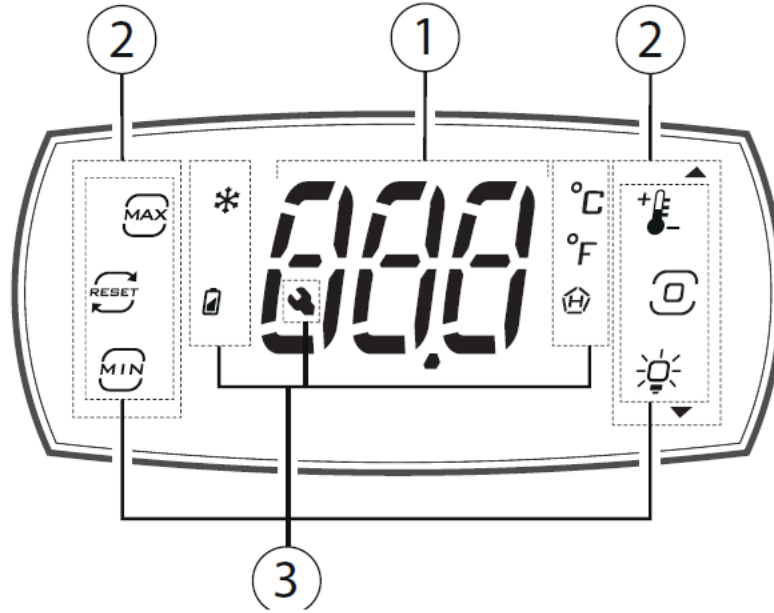

Figure 5. Control Panel

- 1 Display
- 2 Icons/Buttons
- 3 Icons

Table 6. Keypad













Icon/button	Description	On	Flashing
	Minimum temperature	Direct access to minimum recorded temperature	-
	Reset minimum and maximum temperature	Reset minimum and maximum recorded temperatures (requires confirmation)	-
	Maximum temperature	Direct access to maximum recorded temperature	-
	Set point/Up arrow	Increase value Scroll menu	-

Table 6. Keypad

Icon/ button	Description	On	Flashing
	Program	<p>Pressed briefly:</p> <ul style="list-style-type: none"> enter menu branch save value and return to the parameter code <p>Pressed and held (3 s):</p> <ul style="list-style-type: none"> from standby, unlock keypad and enter programming mode when scrolling, go to the previous parameter 	-
	Lights/Down arrow	<ul style="list-style-type: none"> Decrease value or scroll menu Lights on Switch lights on/off 	-
	Compressor	Active	Awaiting
	Battery status	Charging	Needs replacement
	Anomalous temperature	Anomalous temperature alarms present	-
	°C	Unit of measure °C	-
	°F	Unit of measure °F	-
	Service Maintenance	Active alarms	-

Notice: during navigation, the buttons will be on/flashing only if enabled.

Standard display

At start-up, the user terminal briefly shows the firmware version and then the standard display. The standard display depends on the setting of parameter:

- All models (except Pharmacy models) will display the temperature as recorded by the control probe.
- Pharmacy units will display the temperature reported by the independent weighted temperature probe.

Notice: if there is an active alarm, press any button to mute the buzzer. If alarm is still active after 30 minutes, the buzzer will re-activate.





Display active functions and direct access of functions

When pressing any button, the display shows the message "Loc" and the icons corresponding to the currently active functions come on to indicate the status of the unit. On pressing PRG for 3 s, the display shows 3 dashes in sequence and enters direct access mode. In this mode:

- The buttons that are on steady indicate that the corresponding function is active, press the button to deactivate it or access the function;
- The buttons that are flashing indicate that the function is not active and can be activated by pressing the button; When pressing the button, the display shows information on the status of the selected function (On/Off).

Note: If no button is pressed, after 7 seconds the terminal will automatically return to the standard display.

Table 7. Direct Access Icons on User Terminal

Icon	Action in Direct Access Mode
	Direct access to minimum temperature
	Reset minimum and maximum temperatures
	Direct access to maximum temperature
	Direct access to set point
	Lights

Navigation

To navigate the menu tree, use the following buttons:

- UP and DOWN to navigate the menu and set the values;
- PRG to enter the menu items and save the changes made;
- Select the menu item or ESC to return to the previous branch.

Example of how to set parameter St (set point):



1. Wait for the standard display to be shown;



2. Press PRG to enter display currently active functions;

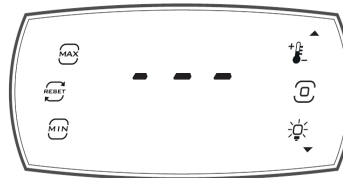

3. Press and hold PRG for 3 seconds to access direct access mode;



4. Press PRG to enter programming mode; the UP and DOWN buttons will flash and the first category of parameters dir (=direct functions) will be displayed;



5. Press DOWN until reaching the parameter category Ctl (=control);

Notice: if no button is pressed, after 20 seconds the terminal will automatically return to the standard display.



- Press PRG to display the first menu item: St (=set point). Press PRG to display the parameter value;



- Press UP/DOWN to modify the value;



- Press PRG to save the setting and return to the menu

CAUTION: if the PRG button is not pressed, the new setting will not be saved;



- Press UP/DOWN to select ESC and press PRG to return to the parameter categories;



- Press DOWN to move to the next category and follow steps 6 to 9 to set the other parameters;





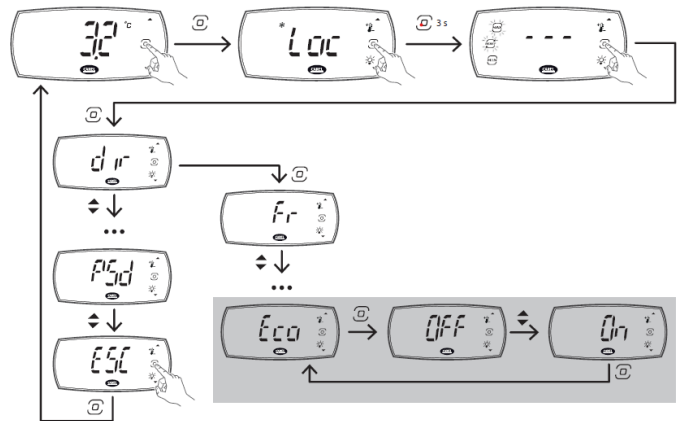

- Once the settings have been made, to exit the categories select ESC and press PRG.



Screens

The possible states of the terminal are shown in the table below.

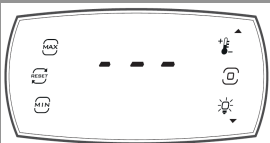
Table 8. Screens

Icon	Status	Description
	Standard	The display shows the main value, alternating with any alarms and signals
	Display active loads	The terminal shows any active loads, the keypad is locked
	Direct access mode	The loads can be activated or deactivated and the direct functions accessed from the keypad
	Programming menu	Scroll the programming menu using the arrow buttons
	Parameter programming /display values	Set the parameters using the arrow buttons or display read-only values

Programming mode

In direct access mode, pressing PRG enters programming mode, where the unit's main operating parameters can be set. To access the Service parameters, go to the "PSD" menu item (see the table below) and enter the password. The user terminal only provides access to the basic configuration parameters, such as direct functions and active alarms without password protection, or, with password protection (Service).

Notice: in the default settings the user password is set to 0 and is not required when entering programming mode; if the password has been set to a value other than 0, this needs to be entered to access programming mode. User will still have access to the Direct Access Mode without entering a password.

The menu items available and parameters visible on the user terminal are listed below.

Table 9. Programming Menu

dir (Direct functions)	nnt	CtL (Control)	Pro (Display probes)	HcP (Temperature alarms)	CnF (Configuration)	ALn (Alarms)	PSD	ESD
See the following table	rL2 (**)	St	/ 5	HAn	Hb	AHA		
	rH2 (**)	Sth	/ cr	HFn	PDU	ALA		
	rt (**)	HU	/ cc	rHP	ESC	Ad		
	ESC	ESC	ESC	ESC		Add		
						rSA		
						ESC		

Temperature settings

The factory default temperature setting is 5°C for all laboratory and pharmacy refrigerators. To change the factory settings, refer to programming instructions.

The refrigerator described in this manual is designed for optimum performance at 5°C. It is advisable to call Technical Service before changing set points.

The recommended set point for NSF 456 vaccine refrigerators is 5°C. Changing this parameter or any other service parameters may affect the units ability to meet the NSF 456 standard.

Direct functions

Table 10. Direct Function Parameters

Acr.	Description
boF	Activate battery storage status
btr	Start battery test
dFn	Start defrost
Eco	Activate Eco mode
Fr	Firmware version
OnF	Unit ON/OFF
SAh	Display alarm log
Sd	Defrost probe
SPr	Product probe
SrG	Control probe
St	Set control set point

Table 11. Programming Parameters

Par.	Menu	Desc.	Def.	Min	Max	UOM
St	Ctl	Temperature control set point	5	4	7	°C/°F
/ 5	Pro	Unit of measure: 0 = °C; 1 = °F	0	0	1	-
Hb	CnF	Enable buzzer: 0 = disabled; 1 = enabled	1	0	1	-
AHA	ALn	High temperature alarm threshold	10	0	555/ 999	Δ °C/ °F
ALA	ALn	Low temperature alarm threshold	2	0	200/ 360	Δ °C/ °F
rL2	nnt	Minimum temperature value in the monitored period	-	-	-	°C/ °F
rH2	nnt	Maximum temperature value in the monitored period	-	-	-	-
rt	nnt	Monitoring period	-	-	-	-
Sth	CtL	Humidity control set point	-	-	-	-
HU	CtL	Humidity level	-	-	-	-
HAn	HcP	Number of type HA alarms	0	0	6	-
HFn	HcP	Number of type HF alarms	0	0	6	-
rHP	HcP	Reset temperature alarm log	0	0	1	-
Ad	ALn	Delay time for high and low temp. alarms (AH,AL)	0	0	240	min
Add	ALn	High temperature alarm bypass time for door open	1	1	240	min
rSA	ALn	Reset alarms	0	0	1	-
PDU	CnF	User password	0	0	999	-
/cc	Pro	Control Probe calibration offset	-	-20	20	Δ °C/ °F
cr	Pro	Product Probe calibration offset	-	-20	20	Δ °C/ °F

Calibration (parameters /cc to /cr)

The controller offers the possibility to calibrate values read by the probes. In particular, parameters /cc to /cr are used to increase or decrease the values read by the probes connected to the analogue inputs, consistently with the unit of measure.

/cc is the control probe calibration offset. The difference in temperature between the control probe value and the average compartment temperature that is used to control the cooling system to the unit setpoint during steady state operation. All units are provided with a factory default setting for optimal cooling control. This can be useful to adjust if there is a discrepancy between the unit setpoint and the average cabinet temperature.

/cr is the product probe calibration parameter. The difference in temperature between the display probe value seen on the User Interface display and the average compartment temperature at the unit setpoint during steady state operation. All pharmacy units are provided with a factory default setting for the display to provide accurate reading compared to the average cabinet temperature. This can be useful to adjust the display during unit calibration procedures.



CAUTION: This modification may not be allowed by site procedures as it alters the measured value. Verify that you have permission to make the modification.

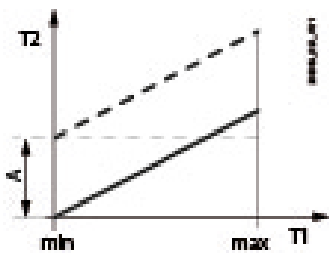

- T1 Temperature read by the probe
- T2 Calibrated temperature
- A Calibration offset
- min, max Field of measurement

Backup battery

The controller can manage an external backup battery. This ensures some minimum controller functions when no power is available, and signals anomalous operation in the event of a

blackout. During normal operation, the controller recharges the battery and performs a test every 24 hours to verify correct operation. The test can also be run manually by pressing a button or via the direct function. Activation of the backup battery can be disabled when the unit is in storage using the boF parameter turned ON within the direct functions. The following battery is supplied with the unit: lead-acid VRLA, 6V, maximum discharge current 200 mA. Typical charging current is 30 mA (maximum 50 mA).



CAUTION: A 500 mA slow-blow fuse (is included) in series with the battery.

Table 12. The table shows the operation of the user interface and the various devices in the event of a power failure:

Function	Behaviour with power failure
Display	The digits go off and only the decimal point remains flashing. Pressing PRG reactivates the standard display for the time bbd
Button backlighting (if present)	PRG button only
Icons	Service icon only flashing
Buzzer	Will be on during alarming and will silenced by pushing the program icon, after 30 minutes the buzzer will reactivate.
Relays	All disabled
Alarms	The power failure is signalled by alarm BLC, visible only by pressing PRG

Notice: In the event of temperature alarms, these are signaled as normal, even in the event of a power failure.

Temperature monitoring

The controller can record the minimum value rL and maximum value rH read by the product probe for pharmacy units and the control probe for the standard units. The monitoring session can be reset at any time, after which the new maximum and minimum values are logged.

See the “Action in Direct Access Mode” for more details.

Alarms and Signals

Signals



Signals are messages shown on the display to notify the user of the control procedures in progress (e.g. defrost) or to confirm keypad input.

Table 13. Signals

Display code	Description
dEF	Defrost running
Loc	Display locked
Off	Switch OFF
On	Switch ON

Types of alarms

The iJS controller can display two types of malfunctions:

- **Warning**, when this type of error occurs, the alarm code is shown on the display, alternating with the main value, and the “Service” icon  is shown on the display, however the buzzer does not sound, no relay is activated; some signals fall under this category, e.g. defrost ended due to maximum time, anomalous temperature alarms, configuration errors.
- **Alarms**, when this type of error occurs, the alarm code is shown on the display, alternating with the main value, and the “Service” icon  comes on, the buzzer flashes and the relay is activated; this category includes alarms for which with the relay is configured as an alarm, probe errors, temperature alarms, frost protection, etc.

Both warnings and alarms can be reset automatically, manually or semi-automatically:

- **Automatic**, when the cause is no longer present, the alarm also ceases;
- **Manual**, when the cause is no longer present, the alarm remains active until manually reset by parameter;
- **Semi- Automatic**, reset is automatic 3 times in an hour, after which manual reset is required.

Active alarms are signaled by the buzzer (see parameter Hb) and the flashing of the “Service” icon . The alarm code is shown on the display, alternating with the main value. Pressing any button mutes the buzzer. If more than one error occurs, these are displayed in sequence. When an alarm is cleared, it is stored in the alarm log containing a maximum of

five alarms, in a FIFO list (the 6th alarm overwrites the 1st alarm, and so on). The error log can be accessed from the user terminal, via supervisor or Applica app (Bluetooth connection only).

Example

Display after HI error.

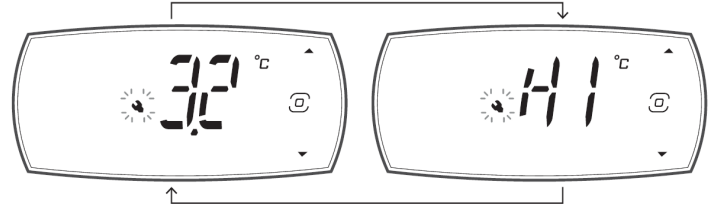

The alarms can be reset manually using parameter rSA, from the user terminal using the specific command on the Alarms page (“Service” or “Manufacturer” level access is required). If the condition that generated the alarm is still present, the alarm will be reactivated after resetting.

Notice: Deleting the alarm log is irreversible.

Alarm table

Table 14. Alarm Table

Display code	Log code	Description	Delay (default)	Icon display	Alarm relay	Buzzer	Reset	Effects on control
Afr	29	Frost protection	Afd (1min)	YES	YES	YES	Automatic	Stop compressor
bAt	39	Battery faulty or not connected	-	YES	YES	YES	Automatic	-
bLC	40	Blackout in progress	-	YES	YES	YES	Automatic	See "Battery status"
btS	41	Battery test in progress	-	NO	NO	NO	Automatic	-
CE	28	Configuration write error	-	NO	NO	NO	Automatic	-
dor	15	Door Open	1 min	YES	YES	YES	Automatic	See "Door management"
E1	1	Probe 1 faulty or disconnected	-	NO	NO	NO	Automatic	According to the connected function
E2	2	Probe 2 faulty or disconnected	-	NO	NO	NO	Automatic	
E3	3	Probe 3 faulty or disconnected	-	NO	NO	NO	Automatic	
Ed1	10	Defrost terminated after maximum time	-	NO	NO	NO	Automatic	-
EHI	36	High power supply voltage alarm	-	YES	YES	YES	Automatic	-
ELO	37	Low power supply voltage alarm	-	YES	YES	YES	Automatic	-
Etc	9	Clock error	-	NO	NO	NO	Manual	-
GHI	19	Generic alarm high threshold	GFA_De (0 s)	YES	YES	YES	Automatic	-
GLO	20	Generic alarm low threshold	GFA_De (0 s)	YES	YES	YES	Automatic	-
HA	21	Type HA anomalous temperature alarm (high temp. during operation)	-	NO	NO	NO	Manual	-
HF	22	Type HF anomalous temperature alarm (high temp. after blackout)	-	NO	NO	NO	Manual	-
HI	24	High temperature	Ad (120 s)	YES	YES	YES	Automatic	-

Table 14. Alarm Table

Display code	Log code	Description	Delay (default)	Icon display	Alarm relay	Buzzer	Reset	Effects on control
IA	13	Immediate alarm from external contact	-	YES	YES	YES	Automatic	Compressor operation in duty setting mode (par. A6); dead band OFF
LO	23	Low temperature	Ad (120 s)	YES	YES	YES	Automatic	-
MAn	38	Output status overridden in manual mode	-	YES	YES	YES	Automatic	-
rE	12	Control probe faulty or disconnected	-	YES	YES	YES	Automatic	Compressor operation in duty setting mode (par. c4); dead band OFF
SF	27	Configuration not completed correctly	-	NO	NO	NO	Manual	-
SrC	35	Maintenance request	-	YES	YES	YES	Manual	-

Low and high temperature alarms LO and HI

Table 15. Low and High Temperature Alarm

Par.	Description	Def.	Min	Max	UOM	User	User terminal
AHA	Absolute high temperature alarm threshold	10°C	-100/ -148	537/ 999	°C/ °F	U	YES
ALA	Absolute low temperature alarm threshold	2°C	-100/ -148	537/ 999	°C/ °F	U	YES

Maintenance



WARNING: Risk of Shock. Disconnect equipment from main power before attempting any maintenance to equipment or its controls unless stated otherwise.

Cleaning the Cabinet Interior

To clean the cabinet interior, remove the shelves or baskets following the instructions in **Shelves, Baskets**. Use a solution of water and a mild detergent for cleaning. Rinse the interior storage components and wipe them dry with a soft cloth.

Compatible cleaning agents include the following: Mild detergent, Hydrogen Peroxide, Acetic Acid, Quaternary ammonium cleaning solutions, and 70% Isopropyl alcohol.

Cleaning the Condenser Filter

Clean the condenser filter every three months. There is one condenser filter located in the back cage of the unit that can be accessed without removing the back cage or disconnecting the power.

To clean the filter, complete the following steps:

1. Remove the filter by pulling upwards through the slot in the back cage.
2. Shake the filter to remove loose dust.
3. Rinse the filter in clean water.
4. Shake the excess water from the filter and let it dry.
5. Reinstall filter by pushing downwards through the slot in the back cage.



CAUTION: Risk of Abrasion. Do not pull the filter downwards from the bottom. The condenser has sharp surfaces.

Cleaning the Condenser



CAUTION: Condensers should be cleaned at least every six months; more often if the laboratory area is dusty. In heavy traffic areas, condensers load with dirt more quickly. Failure to keep the condenser clean can result in equipment warm-up or erratic temperatures.



CAUTION: Risk of Abrasion. Never clean around the condensers with your fingers. Some surfaces are sharp.

The condenser is located in the top rear of the machine compartment. To clean the condenser, complete the following steps:

1. Disconnect the power.
2. Remove the filter.
3. Vacuum the condenser and clean up any loose dust.
4. Replace the filter.
5. Reconnect power.

Automatic Defrost

The defrosting process on all models is primarily accomplished by air circulated during off-cycle periods. This heat-free process ensures that the temperature is not affected by the defrost cycle. The default defrost cycle runs approximately once per hour and terminates once a preset evaporator temperature or timer criteria is reached.

Defrost water is collected in a pan in the rear of the unit and evaporated using system heat. No maintenance is required.

Gasket Maintenance

Periodically check the gaskets around the door for punctures or tears. Leaks are indicated by condensation or frost which forms at the point of gasket failure. Make sure that the cabinet is level (refer to **Location** for leveling information).

Keep the door gaskets clean and frost free by wiping gently with a soft cloth.

To check the door seal, complete the following steps:

1. Open the door.
2. Insert a strip of paper (a couple of inches wide) between the door gasket and the cabinet flange and close the door.
3. Slowly pull the paper strip from the outside. You should feel some resistance.
4. Repeat this test at 4-inch intervals around the door. If the door does not seal properly, replace the gasket.

Alarm Battery Maintenance

Have a certified technician replace the alarm battery every twelve months at most or when the alarm is active. The part number for a replacement battery is 322533H02.

Preparation for Storage

If the unit is going to be stored in an off condition, allow the unit to warm up and dry out with the door open before moving into storage. Access the direct function and change boF to "On".

Note: See operation section for more details about preparing the battery for storage mode.

Probe Recalibration Schedule

The display probe on Pharmacy models should be calibrated every 3 years.

Troubleshooting



WARNING: Troubleshooting procedures involve working with high voltages which can cause injury or death. Troubleshooting should only be performed by Factory Authorized Service Personnel.

This section is a guide for troubleshooting equipment problems. Component parts must be replaced only with like components.

Table 16. Troubleshooting Procedure

Problem	Cause	Solution
Unit does not operate or Power Failure Indicator is on	Power supply	<p>Check that the cord is securely plugged in.</p> <p>Plug another appliance into the outlet to see if it is live.</p> <p>Check that the double pole circuit breaker located next to the power inlet is in “ON” position (i.e “I” position). Try cycling the switch to OFF position (i.e “O” position) and then bring to ON position (“I”).</p> <p>Test the voltage and verify that it is correct for your unit (refer to Table 2).</p> <p>If the outlet is dead, check the circuit breaker or fuses.</p> <p>The unit should not be connected to a GFCI (Ground Fault Circuit Interrupter) protected outlet as it may be subject to nuisance tripping.</p> <p>Reset control</p>
	Control setting too high	<p>If parameter settings have been changed but the unit is not reflecting changed parameters, it is recommended to power the controller off and on again to realign any timings in progress. Wait at least 5 seconds after changing the parameter settings before powering the controller off in order to allow the data to be correctly saved to the memory.</p>
Temperature too high	Inadequate air circulation	Improve air movement
	Temperature control	Make sure that the control is set correctly.
	Condenser clogged	Make sure the condenser is clean.
Temperature fluctuates/ insufficient cooling	Other causes	If the temperature control is set correctly, the condenser is clean, but temperature continues to fluctuate, call an authorized service representative.
	The equipment is not level	Place the equipment on an even surface or use use shims to adjust height at corners, refer to previous installation section for instructions.
The equipment makes too much noise		

Table 16. Troubleshooting Procedure

Problem	Cause	Solution
Unit warms up	Door is open	Make sure the door is completely closed.
	Door seal check	Check the door seal.
	Warm product recently loaded in unit	Allow ample time to recover from loading warm product.
	Power supply	Check for proper voltage to the unit. If there is no voltage to the unit, call an electrician.
	Setpoint is off	Adjust setpoint, refer to previous temp adjustment section in operation section.
Unit noisy	Compressor not functioning	If the compressor is not running and the power failure alarm is on, have an electrician check for proper voltage to the unit. If the compressor is not running and the power failure alarm is off, call the customer service for assistance.
	Loose parts or mountings	Find and tighten.
Condensation around door frame	Gaps exist in unit port holes	Ensure all port holes in the cabinet top, sides, and back are sealed properly to prevent warm airflow into the cabinet. Seal any gaps.
	Door seal is broken	Verify nothing is placed through the door seal such as a sensor. Check the door seal following instructions in Section 12.5.

End of Life Care

Some considerations and suggestions are listed below for proper disposal of this product. While addressing these actions for safe recycling and disposal, please follow all guidelines, Safety Data Sheets (SDS), or regulations applicable to your country and region.

- This product contains materials and components which may be recycled or reused according to local guidelines and regulations.
- Remove any batteries present before disposal. Batteries, battery packs, and accumulators should not be disposed of as unsorted household waste. Please use the public collection system to return, recycle, or treat them in compliance with the local regulations.
- Remove all samples and items before defrosting a unit to room ambient temperatures.
- Clean up any chemical or biological safety hazards using appropriate methods.
- Remove the cabinet door to help prevent entrapment inside of a unit.
- Have a certified technician remove the refrigerant and compressor, drain the compressor and oil from the system, and dispose properly. Note that oil may be infused with refrigerant and should be handled with care by someone experienced with refrigerants used in this product, as listed on the serial data plate.

Warranty

International Warranty • 48 Months Parts and Labor, 5 years for compressor parts

During the first forty eight (48) months from shipment, Thermo Fisher Scientific Inc, through its authorized Dealer or service organizations, will at its option and expense repair or replace any part found to be non-conforming in material or workmanship. Thermo Fisher Scientific Inc reserves the right to use replacement parts, which are used or reconditioned. Replacement or repaired parts will be warranted for only the unexpired portion of the original warranty.

This warranty does not apply to damage caused by (i) accident, misuse, fire, flood or acts of God; (ii) failure to properly install, operate or maintain the products in accordance with the printed instructions provided, (iii) causes external to the products such as, but not limited to, power failure or electrical power surges, (iv) improper storage and handling of the products, (v) use of the products in combination with equipment or software not supplied by Thermo Fisher; or (vi) installation, maintenance, repair, service, relocation or alteration of the products by any person other than Thermo Fisher or its authorized representative. To obtain proper warranty service, you must contact the nearest authorized service center or Dealer. Thermo Fisher Scientific, Inc's own shipping records showing date of shipment shall be conclusive in establishing the warranty period. At Thermo Fisher's option, all nonconforming parts must be returned to Thermo Fisher postage paid and replacement parts are shipped FOB Thermo Fisher's location.

Limitation of Liability:

THIS WARRANTY IS EXCLUSIVE AND IN LIEU OF ALL OTHER WARRANTIES, WHETHER WRITTEN, ORAL, OR IMPLIED. NO WARRANTIES OF MERCHANTABILITY OR FITNESS FOR A PARTICULAR PURPOSE SHALL APPLY. THERMO FISHER DOES NOT WARRANT THAT THE PRODUCTS ARE ERROR-FREE OR WILL ACCOMPLISH ANY PARTICULAR RESULT.

THERMO FISHER SHALL NOT BE LIABLE FOR ANY INDIRECT OR CONSEQUENTIAL DAMAGES INCLUDING, WITHOUT LIMITATION, DAMAGES TO LOST PROFITS OR LOSS OF PRODUCTS.

Regulatory Compliance

Product Safety

Product Testing

This product family has been tested to applicable product safety standards by a Nationally Recognized Test Laboratory (NRTL) and may bear the NRTL's mark of safety compliance to those applicable standards.



Hydrocarbon Refrigerants

According to U.S. Code of Federal Regulation 40 Part 82, this refrigerator employs the natural hydrocarbon refrigerant R290. Because of the nature of hydrocarbon refrigerants, for mechanical repair, such as recharge or compressor replacement, should only be carried out by a certified refrigeration technician. The safety of this equipment is listed by Underwriter Laboratory (UL) under Standard UL471, section SB – “natural refrigerant”.

Electromagnetic Compatibility

FCC Statement (USA)



This device complies with Part 15 Subpart B of the FCC Rules. Operation is subject to the following two conditions: (1) this device may not cause harmful interference, and (2) this device must accept any interference received, including interference that may cause undesired operation. Any changes or modifications not expressly approved by the manufacturer could void the user's authority to operate the equipment.

Note: This equipment has been tested and found to comply with the limits for a Class A digital device, pursuant to part 15 of the FCC Rules. These limits are designed to provide reasonable protection against harmful interference when the equipment is operated in a commercial environment. This equipment generates, uses, and can radiate radio frequency energy and, if not installed and used in accordance with the instruction manual, may cause harmful interference to radio communications. Operation of this equipment in a residential area is likely to cause harmful interference in which case the user will be required to correct the interference at his own expense.

Canadian ISED IC Notice

This ISM device complies with Canadian ICES-001, Class A.

Cet appareil ISM est conforme à la norme NMB-001 du Canada, Classe A.

Korean KC Registration



사용자 안내문 이 기기는 업무용 환경에서 사용할 목적으로 적합성평가를 받은 기기로서 가정용 환경에서 사용하는 경우 전파간섭의 우려가 있습니다.

WARNING: EMC Registration is done on this equipment for business use only. It may cause interference when the product would be used in home.

European Union



The European voltage models of this product meet all the applicable requirements of the European Directives and therefore display the CE Marking. These Directives are captured in the EU Declaration of Conformity which may be obtained from the manufacturer.

Energy Efficiency

ENERGY STAR



This product family has been voluntarily evaluated, and found compliant, by an EPA approved certification body to the EPA ENERGY STAR Laboratory Grade Refrigerators and Freezers Specification 1.1. Details can be found in the product Technical Specification Sheet or Online at energystar.gov.

This page
is intentionally
left blank

WEEE Compliance

WEEE Compliance. This product is required to comply with the European Union's Waste Electrical & Electronic Equipment (WEEE) Directive 2012/19/EU. It is marked with the following symbol. Thermo Fisher Scientific has contracted with one or more recycling/disposal companies in each EU Member State, and this product should be disposed of or recycled through them. Further information on our compliance with these Directives, the recyclers in your country, and information on Thermo Scientific products which may assist the detection of substances subject to the RoHS Directive are available at www.thermofisher.com/WEEERoHS.

Great Britain



WEEE Konformität. Dieses Produkt muss die EU Waste Electrical & Electronic Equipment (WEEE) Richtlinie 2012/19/EU erfüllen. Das Produkt ist durch folgendes Symbol gekennzeichnet. Thermo Fisher Scientific hat Vereinbarungen getroffen mit Verwertungs-/Entsorgungsanlagen in allen EU-Mitgliedstaaten und dieses Produkt muss durch diese Firmen verwertet oder entsorgt werden. Mehr Informationen über die Einhaltung dieser Anweisungen durch Thermo Scientific, die Verwerter und Hinweise die Ihnen nützlich sein können, die Thermo Fisher Scientific Produkte zu identifizieren, die unter diese RoHS-Anweisungen fallen, finden Sie unter www.thermofisher.com/WEEERoHS.

Deutschland



Conformità WEEE. Questo prodotto deve rispondere alla direttiva dell'Unione Europea 2012/19/EU in merito ai Rifiuti degli Apparecchi Elettrici ed Elettronici (WEEE). È marcato col seguente simbolo. Thermo Fisher Scientific ha stipulato contratti con una o diverse società di riciclaggio/smaltimento in ognuno degli Stati Membri Europei. Questo prodotto verrà smaltito o riciclato tramite queste medesime. Ulteriori informazioni sulla conformità di Thermo Fisher Scientific con queste Direttive, l'elenco delle ditte di riciclaggio nel Vostro paese e informazioni sui prodotti Thermo Scientific che possono essere utili alla rilevazione di sostanze soggette alla Direttiva RoHS sono disponibili sul sito www.thermofisher.com/WEEERoHS.

Italia



Conformité WEEE. Ce produit doit être conforme à la directive européenne (2012/19/EU) des Déchets d'Équipements Électriques et Électroniques (DEEE). Il est marqué par le symbole suivant. Thermo Fisher Scientific s'est associé avec une ou plusieurs compagnies de recyclage dans chaque état membre de l'union européenne et ce produit devrait être collecté ou recyclé par celles-ci. Davantage d'informations sur la conformité de Thermo Fisher Scientific à ces directives, les recycleurs dans votre pays et les informations sur les produits Thermo Fisher Scientific qui peuvent aider la détection des substances sujettes à la directive RoHS sont disponibles sur www.thermofisher.com/WEEERoHS.

France





IF YOU NEED ASSISTANCE:

Thermo Fisher Scientific products are backed by a global technical support team ready to support your applications. We offer cold storage accessories, including remote alarms, temperature recorders, and validation services.

Visit www.thermofisher.com/cold or call:

Countries	Sales
North America	+1 866 984 3766
India toll free	1800 22 8374
India	+91 22 6716 2200
China	+800 810 5118, +400 650 5118
Japan	+81 3 5826 1616
Australia	+61 39757 4300
Austria	+43 1 801 40 0
Belgium	+32 53 73 42 41
France	+33 2 2803 2180
Germany international	+49 6184 90 6000
Germany national toll free	0800 1 536 376
Italy	+32 02 95059 552
Netherlands	+31 76 579 55 55
Nordic/Baltic/CIS countries	+358 9 329 10200
Russia	+7 812 703 4215
Spain/Portugal	+34 93 223 09 18
Switzerland	+41 44 454 12 22
UK/Ireland	+44 870 609 9203
New Zealand	+64 9 980 6700
Other Asian Countries	+852 2885 4613
Countries not listed	+49 6184 90 6000

Thermo Fisher Scientific (Asheville) LLC
275 Aiken Road
Asheville, NC 28804
United States

Find out more at thermofisher.com/cold

