

**Operating Instructions
Thermo Scientific Barnstead LabTower RO
Water Purification System**

[] Art. no.: 50132392 RO 60

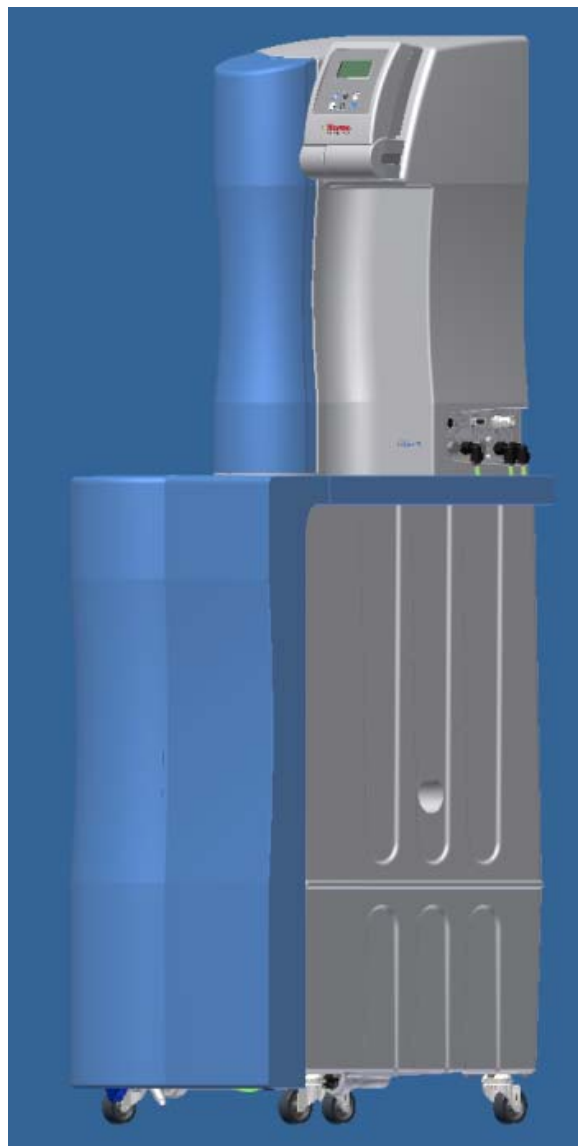

Serial no.:

These Operating Instructions must be read prior to installing and starting the system!

50133023, Stand: 10.12 Rights to technical changes reserved!

EC Declaration of Conformity

according to EC Machines Directive 2006/42/EC, Appendix II A

We herewith declare that the design and construction of the machines named below, and the versions of it that we have introduced into the market, conform to the fundamental safety and health requirements of EC Directive 98/37/EC.

This declaration is invalidated when changes which were not agreed to by us are made to the machine.

Manufacturer: Thermo Electron LED GmbH
Stockland 3
56412 Niederelbert, Germany

Description of the machine:

Function: Pure water system

Versions: LabTower RO

Article numbers: 50132392

We also declare that the machine complies with the following further appropriate Guidelines/Directives:

EMV Directive (2004/108/EC)

Harmonized Standards applied:

DIN EN ISO 12100-1 Safety of machines, Part 1: Principles
DIN EN ISO 12100-2 Safety of machines, Part 2: Technical Guidelines
DIN EN ISO 14121-1 Safety of machines, Part 1: Risk assessment
DIN EN 61326-1

Person authorized for documentation:

Detlef Opp
Stockland3
D-56412 Niederelbert

Niederelbert, 1. April 2010

Detlef Opp, Head of Technical Documentation



Signature

Preface

Dear Sir or Madam,

In deciding to purchase a high-purity water system of type **LabTower RO** you have selected a high-quality product.

Thank you for the confidence you have placed in us.

Before you start to install and operate your pure water system, please carefully read the information given in these Operating Instructions on how installation and operation are to be properly carried out.

This is particularly important, as we, the manufacturer, cannot accept liability for any damage occurring as a result of improper operation of this system, or from use of it for other than the intended purpose.

Niederelbert, 01.04.2010

1. Contents

Preface.....	3
1. Contents.....	4
2. Explanatory notes on the operating instructions	6
3. Transport and packaging	7
3.1 Examination on receipt.....	7
3.2 Complaints	7
3.3 Packaging and return shipment.....	7
4. Extent of delivery	8
5. Safety precautions	9
6. Intended use	10
7. Technical specifications	11
8. Flow chart	13
9. How the system functions	15
10. The installation area.....	17
11. Installation.....	18
12. Installation - Putting into operation.....	20
12.1 Mounting the power pack (voltage supply).....	22
13. Operating elements.....	23
14. System control	24
14.1 User menu.....	24
14.1.1 Feedwater conductivity:	24
14.1.2 Permeate limiting value:	25
14.1.3 Operating hours:	25
14.1.4 Operating hours, pretreatment:.....	26
14.1.5 Cleaning:.....	26
14.1.6 Disinfection:	27
14.1.7 Fault storage:.....	27
14.1.8 Unlocking the system:.....	28

14.2 OEM Menu	30
14.2.1 Maximum Temperatur:	30
14.2.2 Disinfection time:	31
(not active in this system version)	31
14.2.3 Recirculation time:	31
14.2.4 Rinsing time:	31
14.2.5 Interval rinse time:	32
14.2.6 Real-time clock:	32
14.2.7 Sending interval:	32
14.2.8 Language:	33
14.2.9 Switching units:	33
14.2.10 Switch off temperature compensation:	33
14.2.11 Adjusting the float switch circuit hysteresis:	34
14.2.12 Programme choice TII UV/ RO:	34
14.2.13 Entering the system type and serial number:	34
Pacific RO / Pacific TII / Pacific TII UV / Pacific AFT	34
14.3 Printer output	35
14.3.1 Standard messages:	35
14.3.2 Code messages:	35
14.3.3 Fault messages:	35
15. Maintenance	36
15.1 Maintenance intervals	37
15.2 Rinsing membranes	37
15.3 Replacing the pretreatment	38
15.4. Replacing the RO-membranes	40
15.5 Changing the filter cartridge	41
15.6 Disinfection	42
16. Waste disposal	44
17. Trouble shooting	45
18. List of replacement parts	48
19. Consumable materials	50
21. Terminal assignment	51
22. Maintenance record	53

2. Explanatory notes on the operating instructions



EU Mark of Conformity



CSA - admission



Important operating and/or maintenance instructions! Read the operating instructions with due care.



Risk of electric shock! Electrical work on the system is only to be carried out by qualified personnel.



General information! Particularly important notes are marked with this information sign.



Protective conductor connection

The information provided in these operating instructions is only valid for the system which has the serial number which is to be entered on the front page.



Please enter the serial number* of your LabTower RO system in the space provided on the front page.

* Read the serial number of your pure water system from the type plate.

For quick and correct service, please include the following information on all inquiries and replacement parts orders which relate to your system:

- The serial number
- The article number

3. Transport and packaging

Pure water systems are carefully checked and packed prior to shipment but despite this there is always a possibility that damage could occur to them during shipment.

3.1 Examination on receipt

- Check the completeness of the delivery against the shipping papers.



Is the packaging damaged ?

- Check the system for damage.

3.2 Complaints

Should the system have been damaged during transport:

- Immediately contact the post office, railway or forwarding agent*.
- Keep the packaging, including the outer cardboard box, for a possible inspection and/or return shipment.

3.3 Packaging and return shipment

Whenever possible use the original packaging and packing materials.

Should these no longer be available:

- Pack the system in packing film and then in a strong cardboard box so that it is held shock-proof.



*** Complaints are only valid for 6 days (after receipt of the goods).
After this time, the right to claim for damages expires.**

4. Extent of delivery

The LabTower RO pure water system consists of:

1 x	LabTower RO 60	Article no.: 50132392
1 x	Assembly kit consisting of:	Article no.: 50133022
1 x	Prefilter cartridge 5µm + hardness stabilization, 10"	Article no.: 06.5204
1 x	Fine filter 1µm-10"	Article no.: 06.5101
1 x	Connecting kit consisting of:	Article no.: 25.0085
3 x	Connecting hose, PE, Ø8/Ø6 x 3m	Article no.: 18.0036
2 x	POM Insert	Article no.: 14.0189
2 x	Gasket, 3/4"	Article no.: 21.5008
2 x	Union nut, R 3/4"	Article no.: 14.0003
2 x	Screw-in connector, Ø8-1/4"	Article no.: 14.0075
1 x	Operating Instructions	Article no.: 50133023
1x	Connecting cord (rubber connector to nema plug connector)	Article no.: 50132200
1x	Connecting cord (rubber connector to british ST plug connector)	Article no.: 50132203
1x	Connecting cord (rubber connector to euro plug connector)	Article no.: 50132215
1x	Table power unit 48V DC	Article no.: 50134184
1x	Universal adapter	Article no.: 21.1006
1x	Universal holder	Article no.: 21.1007



**Please check the parts delivered against this list.
Contact the manufacturer should a part be missing.**

5. Safety precautions



For your own safety, please observe the above safety precautions!

- The LabTower RO system is a modularly constructed pure water system which is intended to be used solely for further purifying tap water.
- Do not start or operate the system until you have read through the corresponding information that is given in these Operating Instructions.
- Lifting and carrying the pure water system, e.g. to the installation location, should be carried out by two people. To lift it, each takes hold of it under the base plate at two corners.
- Note that the manufacturer is freed from all liability for damages that result from improper operation of the system, or from use of it for other than the intended purpose.
- The CE-Mark becomes invalidated when constructional changes are made to the system or products of other manufacturers are installed in it.
- Protect the system from frost. The temperature in the room where it is installed must be at least +2°C and at most +40°C.
- Observe all regulations and requirements that are in force at the area in which the system is installed and the statics of the flooring (see “Technical specifications” for the weight) as well as the valid accident regulations.
- The feedwater pressure must be at least 2 bar and at most 6 bar. An additional pressure pressure must be installed should the feedwater pressure be higher.
- DIN EN 1717 requires that water purification systems be equipped with a safety device that protects the drinking water system from contamination.
- A grounded 100-250V, 50/60Hz socket must be available.
- The installation area must have a drain at floor level with at least DN 50 pipe, otherwise the manufacturer will not accept any liability for water damage. A water watcher (240V only) (article no. 16.0129) must be installed should no such drain be available
- Gravity fall to the waste drain must be ensured.
- After long standstill periods (e.g. long holidays), the system must be subjected to cleaning and, if appropriate, disinfection. Refer to the “Cleaning and disinfection” section for details.
- When selecting the installation area and installing the system, make sure that there is sufficient working area around the system for convenient operation of it.
- Never look directly into a switched-on UV-lamp, as UV-light is dangerous to eyesight. The UV-lamp is only to be replaced by authorized person to do this.
- The guarantee is valid for a period of 12 months.

6. Intended use

The LabTower RO pure water system is a reaction to the continually increasing requirements that water of pure quality must fulfil, the increasingly strict demands resulting from technological advances and the need for user-friendly systems and complete solutions.

LabTower RO systems have been solely and specifically designed to excel in the intended use, which is to produce sterile filtered pure water free of particles, salts and organic compounds.

To benefit from the long possible service lives of the high-quality purification media, feed the pure water system with water which has been subjected to an upstream pre-treatment step (reverse osmosis, ion exchange or distillation),

- Analytical techniques in laboratories:

- HPLC (**H**igh **P**erformance **L**iquid **C**hromatography)
- IC (**I**on **C**hromatography)
- ICP (**I**nductive **C**oupled Argon **P**lasma)
- AAS (**A**tom ic **A**bsorption **S**pectrophotometry)
- TOC Analysis (**T**otal **O**rganic **C**arbon)
- DNA Research
- etc.

- Reagent and solution preparation:

- Cell culture media
- Tissue culture media
- Make-up water for reagents for on-line analytical systems

- Water for high-purity rinse processes on a laboratory scale

7. Technical specifications

Demands on the feedwater	
Source	Potable tap water that has been softened or hardness stabilized.
Silt density index (SDI)	< 5. With higher values a pretreatment (article no. 09.4000) must be installed upstream of the system.
Resistance	> 0.001 MΩxcm
Prefiltration	5µm + hardness stabilization
Free chlorine	< 0.1 mg/L
Manganese content	< 0.05 mg/L
Iron content	< 0.05 mg/L
Colloid index	< 3
pH-Range	4 - 11
Temperature	2 - 35 °C
Pressure	2 - 6 bar

Pure water quality	
	LabTower RO
Salt retention quota	Ø 98 %
Retention quota for bacteria and particles	99 %
Performance	60 L/h

Dimensions	
Height	1500 mm
Width	450 mm
Depth	580 mm
Weight empty	49 kg
Weight in operation (with full tank)	149 kg

Cell constants of the measuring cells	
Conductivity, feedwater	0.16 cm ⁻¹
Conductivity, permeate	0.16 cm ⁻¹

Water connectors	
Raw water inlet	Hose, 8 mm o.d.
Concentrate outlet	Hose, 8 mm o.d.
Pure water outlet	Hose, 8 mm o.d.

Electrical connections / external switched mode power supply	
Input voltage	AC 100 – 250 V, 50 – 60 Hz, 4 – 2.5 A
Output voltage	DC 48 V, 2.5 A
System connection	DC 48 V, 120 W
Serial interface	RS 232

Airborne sound emission	
Sound-pressure level	49 db(A)

Ambient conditions (DIN EN 61010-1 (VDE 0411-1):2011-02)	
Usage	Indoor rooms
Height	Up to 2000 m
Temperature range	From 5° C to 40° C
Relative humidity	Maximum relative humidity 80 % at temperatures of up to 31° C, linearly decreasing to 50 % relative humidity at 40° C
Line-voltage variation	Not more than ± 10 % of the line voltage
Transient overvoltages	As usually occur in the supply network (overvoltage category II acc. to IEC 60364-4-443). <u>Note:</u> The rated level of transient overvoltage is the withstand impulse voltage acc. to overvoltage category II of IEC 60364-4-443
Ventilation requirements	There are no special requirements with regard to ventilation.
Degree of pollution	2

Materials of parts that contact water	
Pump head	Nylon with glass fibre
Filter cartridge	PP
Rinsing solenoid valve	PA
Dispensing valve	PVDF
Conductivity measuring cells	POM, stainless steel
Distributor block	POM
Connectors	POM
Hoses	PE
O-Rings	EPDM

8. Flow chart

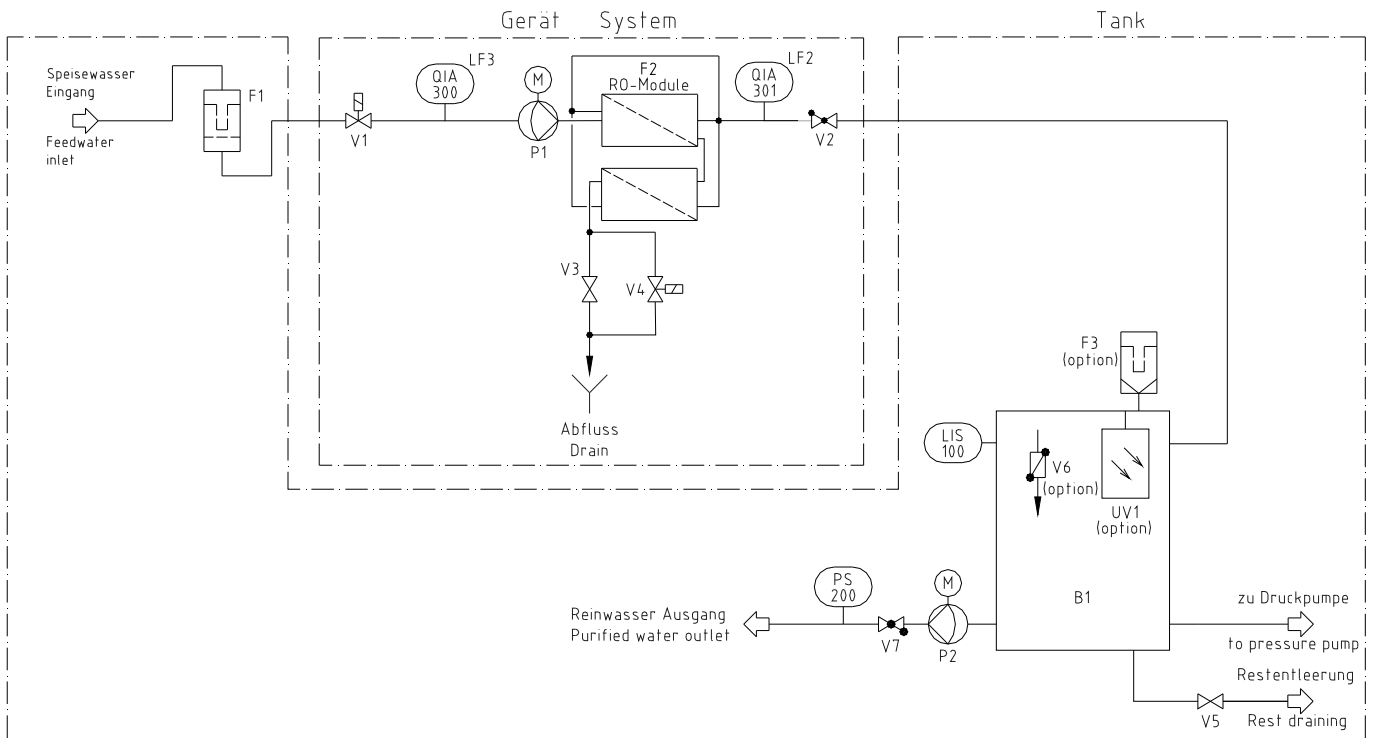

B1 Storage tank:	Stores the pure water that is produced.
F1 Prefilter 5µm + hardness stabilization:	Prevents the penetration of particles > 5µm. Stabilizes calcium and magnesium.
F2 RO Module:	Semipermeable thin-film composite spiral wound membrane.
F3 Sterile vent filter (option)	Prevents the penetration of bacteria and particles > 0,2 µm from the surrounding air.
LIS100 Float switch:	Determines the filling level in the storage tank.
P1 Pressure booster pump:	Raises the input pressure to the required operating pressure.
P2 Pressure pump:	Pumps pure water to the user during pure water withdrawal.
PS200 Pressure switch:	Switches pressure pump (P2) on when pure water is taken from storage tank (B1) and off when user withdrawal stops.
QIA300 Conductivity measuring cell for feedwater:	Measuring device for the determination of the conductivity as a parameter of feedwater quality.
QIA301 Conductivity measuring cell for pure water:	Measuring device for the determination of the conductivity after RO) as a pure water quality parameter.
UV1 UV-Disinfection: (option)	Serves to hinder bacterial growth and the formation of a bio-films on the inside surfaces of the storage tank.

- V1 Feedwater solenoid valve: Is closed during stand-By and standstills and so prevents water from flowing into the system when the system is not in operation.
- V2 Check valve: Prevents measuring cell (QIA301) from being emptied of water.
- V3 Pressure hold valve: Serves for adjustment of the operating pressure and the WCF.
- V4 Rinsing solenoid valve: Opens for membrane cleaning prior to pure water production, after pure water production and at least every 12 hours.
- V5 Residual drainage Enables storage tank (B1) to be completely emptied.
- V6 Sterile overflow:
(option) Prevents bacteria and other microorganisms from entering the system.
- V7 Check valve: Prevents pure water from flowing back into storage tank (B1).

9. How the system functions

After switching the ON / OFF - key to on, the system starts either in the production mode or stand - by mode, according to the filling level in the storage tank.

Feedwater flows into the system under a maximum pressure of at least 2 bar or at most 6 bar.

Feedwater solenoid valve (V1) is closed in stand-by mode and during standstills. It prevents feedwater from flowing into the system when the system is not in operation and so protects against overflowing of the storage tank (B1).

From feedwater solenoid valve (V1) the feedwater flows across feedwater measuring probe (QIA 300) and on through pressure booster pump (P1) to the RO membranes in RO-module (F2).

The semi-permeable membranes (F2) retain all salts that are dissolved in the water according to their given retention quota. In addition, because of the molecular size of the membrane pores, an average 99% retention of bacteria, pyrogens and particles is also ensured.

The pure water now flows across pure water measuring probe (QIA 301) into storage tank (B1). The measured value can be read from the display.

The constituents removed from the water are led away in the remaining concentrate.

The value measured by measurement probe (QIA 300) can be called in the microprocessor control menu.

Pressure pump (P2) pumps the pure water that is in storage tank (B1) to the pure water outlet / user via check valve (V7).



Valve V3 has been pre-adjusted in the factory. A change in the adjustment of this valve could result in damage to the reverse osmosis module. Because of fluctuations in the feedwater temperature and pressure, the setting of the pressure hold valve and the concentrate flow that it governs must be checked and, if necessary, re-adjusted, when the system is put into operation and at regular intervals thereafter. The measured values must be entered in the maintenance record.

Concentrate flows for LabTower RO		
Check and possibly readjust at least once monthly		
System	Permeate flow [L/h]	Concentrate flow [L/h]
LabTower RO 60	60	100

Your pure water system is equipped with automatic flushing. Flushing is carried out when the system is switched on, at the end of each production, and also every 12 hours. For this, rinsing solenoid valve (V4) is opened and the strong flow of water across reverse osmosis module (F2) sweeps coarse particles and other contaminants away from the surface of the membranes and carries them with it to drain.

This automatic flushing has a positive effect on the service life of the reverse osmosis module.

An additional advantage of automatic flushing is that it prevents bacterial growth from occurring in the reverse osmosis module when the system is at a standstill for a long time. For this reason, we expressly recommend that you leave the system switched on over the weekend and during holiday times, so that the 12 hour flush can effectively guard against bacterial growth.

10. The installation area

Take the following criteria into consideration when selecting the installation area:

- Feedwater pressure, not below 0.1 bar and not above 6 bar.



The feedwater pressure must never exceed 6 bar. If it is higher than this, install an additional pressure reducer.

- Minimum temperature + 2°C.
- Level standing surface.
- A smooth wall is required when the system is to be wall-mounted. Check the statics of the wall. It must have sufficient load-bearing capacity (for system weight, see "Technical Specifications").
- A floor drain with a DN 50 size waste pipe.
- Free run off to drain.
When no floor drain is available, install a water watcher (240V only) (article no.: 16.0129) to protect against water damage!



Unrestricted gravity flow to drain must be ensured!

- An electrical socket appropriate for the system (see "Technical Specifications").
- Sufficient working room around the system (for replacing filters etc.).
- Easy access for operation and control of the system.
- Tap water connection with R 3/4" thread.

11. Installation

- Before the pure water system can be put into operation, it must be moved to the back of designated wall with screws.

Note: The distance from the pure water system to the wall is 20 mm.
- Use the assembling kit available in wall bracket, the 2 screws 4x40 mm and the 2 dowels (Ø 6 mm)
- Plug the wall bracket into the backside of the pure water attachment, as shown graphically on the following page.
The wall bracket must shown with the notches (see position "X") down.
- Now position the pure water system at the proposed wall and attach it with the dowels and screws.

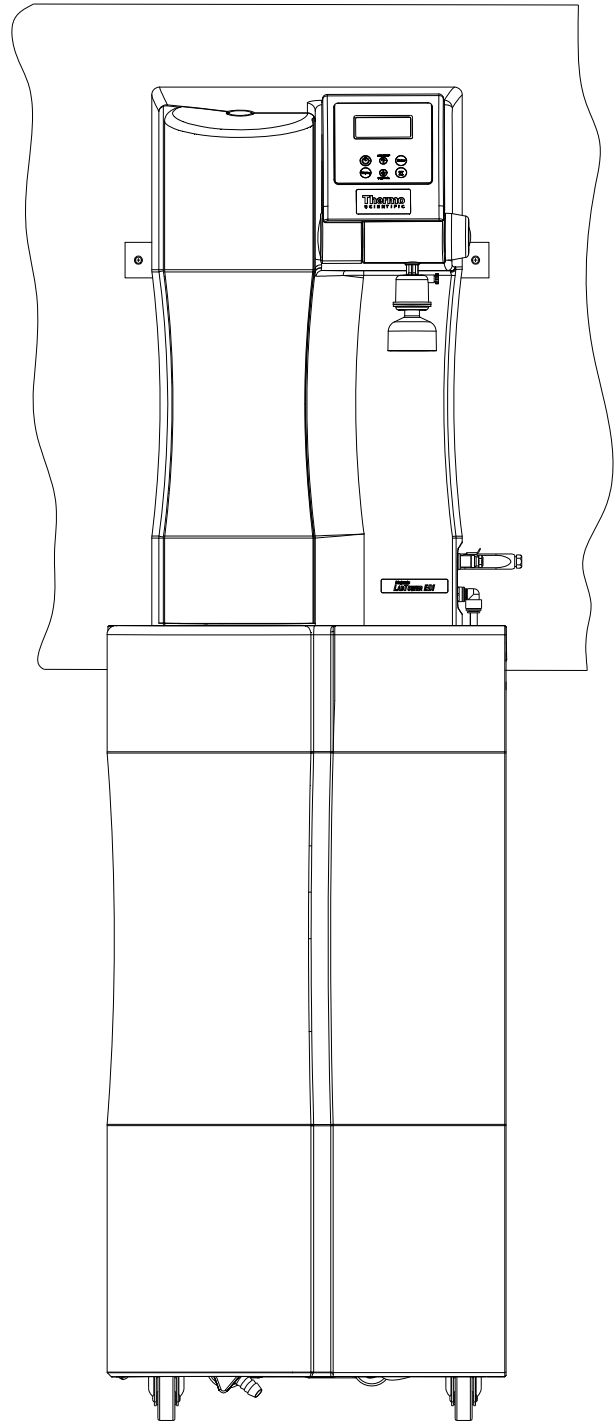
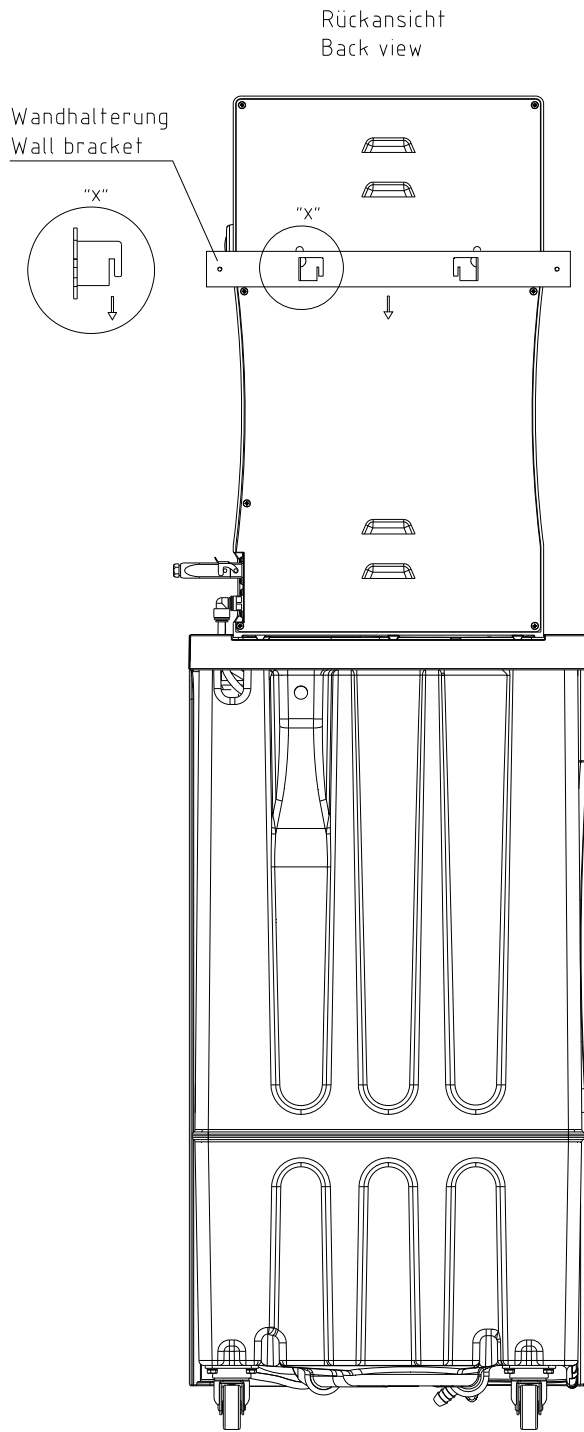

Wandhalterung / Maße
Wall bracket / dimensions

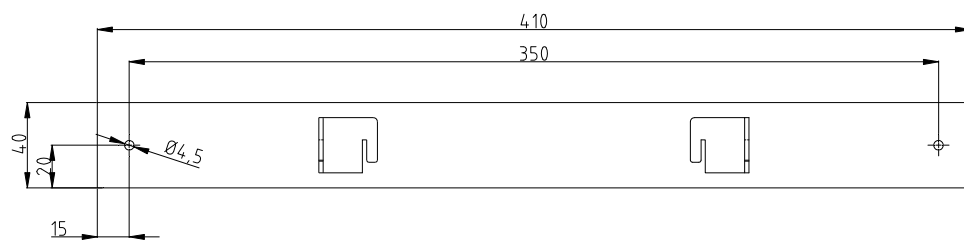

12. Installation - Putting into operation

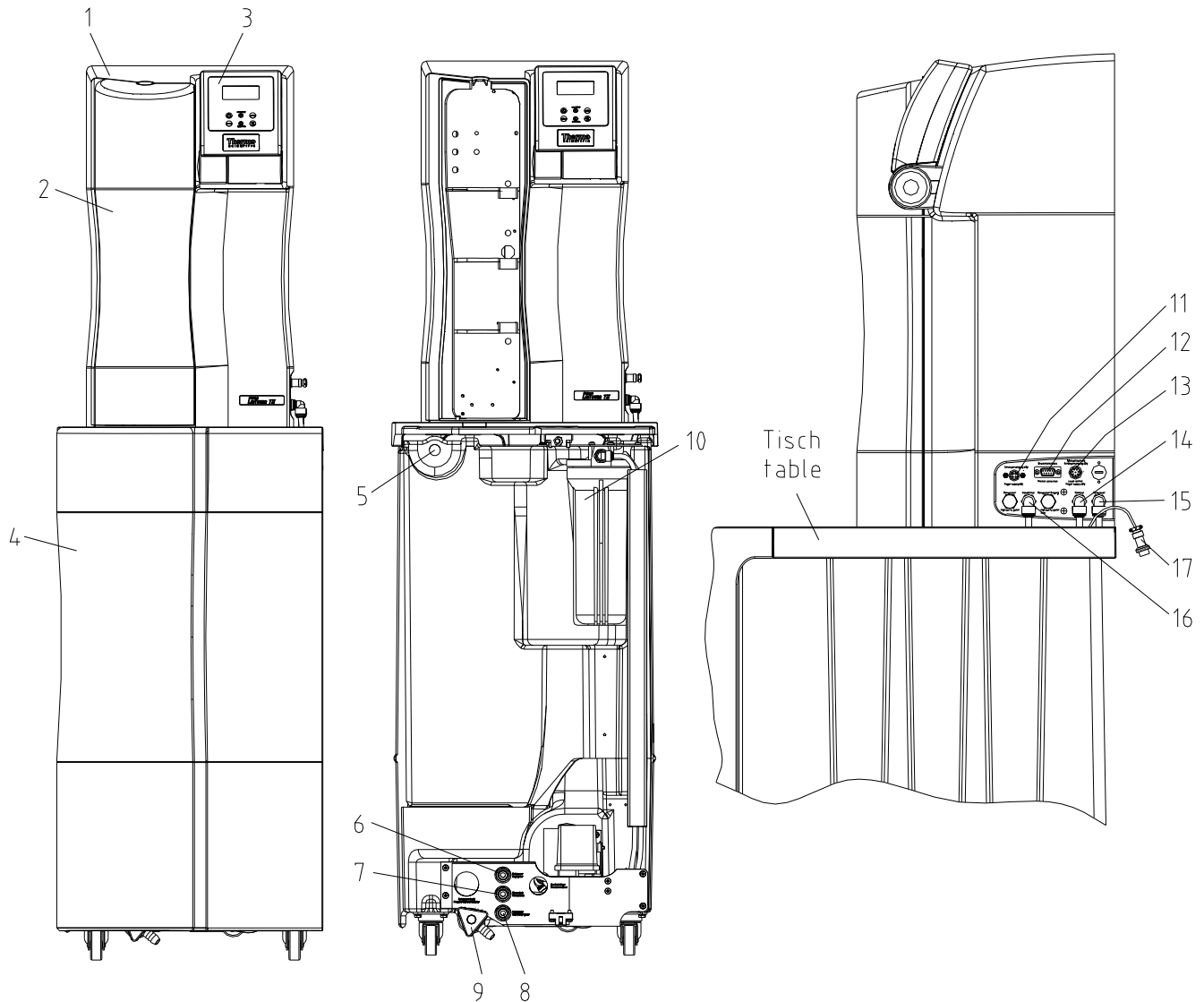

- | | | | |
|-----|----------------------------------|-----|---|
| 1) | Labtower RO 60 pure water system | 12) | Printer connector |
| 2) | Front cover, removable | 13) | Socket for level control, power supply pressure booster pump / storage tank |
| 3) | Operating unit | | |
| 4) | Front cover, storage tank | 14) | Connector, permeate |
| 5) | Sterile vent filter (option) | 15) | Connector, feedwater |
| 6) | Feedwater inlet | 16) | Connector, concentrate |
| 7) | Concentrate outlet | 17) | Plug for level control, power supply pressure booster pump / storage tank |
| 8) | Pure water outlet | | |
| 9) | Residual drainage | | |
| 10) | Pretreatment | | |
| 11) | Power supply, 48V DC | | |

1. Place the pure water system on the storage tank table. Connect the hoses positioned on the table to the appropriate system connectors (14-16) using the angled connectors.
2. Take off front cover (4) from the storage tank.
3. Turn pretreatment filter housing (10) to take it off. Insert the pretreatment unit (prefilter + hardness stabilization) which is provided in the assembly kit in the pretreatment filter housing and screw this tightly back on (see the "Replacing the pretreatment" section).
4. Connect the Ø8 – ¾" i.d. hose that is provided in the connector kit to storage tank feedwater inlet (6) and to a water tap that can be turned off. The connector on the storage tank is marked "Raw water".
5. Connect the 8 mm diameter hose supplied to concentrate outlet (7) on the storage tank and lead it to the on-site drain. The connector is marked "Concentrate". The drain to the sewer must be max. Are 1 m above the rinsing water connector of the unit.

Important! The concentrate must be able to flow to drain under free gravity fall!

6. Connect 4-pin plug (17) for the level control (storage tank) and voltage supply (pressure pump) to the 4-pin socket (13) of the pure water system and screw the milled nut of the plug tight.
7. Screw the (optional) sterile vent filter (5) onto the storage tank.
8. Now fit the (optional) 8 mm diameter sterile overflow hose to the overflow at the back of the tank and connect it to the drain.



The sterile overflow will only function perfectly when the tank lid is tightly closed.

9. Check that the residual drainage (9) is closed.
10. Check the feedwater pressure; it must be within the permissible pressure range (see "Technical specifications").
11. Turn on the feedwater supply.
12. Plug the mains plug in.



Before you now switch the system on, read through the rinsing out procedure for reverse osmosis membranes that are supplied in preserving agent in the "Rinsing membranes" section!

13. Use the on/off key of operating unit (3) to switch the pure water system on.
14. Check that all connections are leak-tight.
15. Fit front cover (4) back on the storage tank.

The system is now ready to operate.

12.1 Mounting the power pack (voltage supply)

Rückseite / Netzteil
Back side / power supply

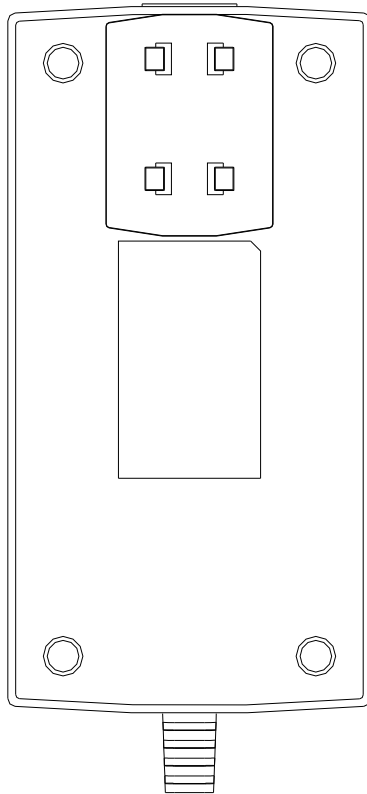

Universaladapter
Universal adapter

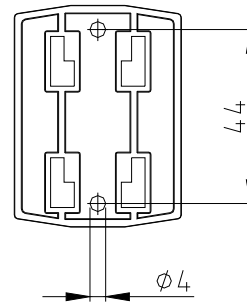

Befestigung
mit Schrauben

Fixing with screws

- Whenever possible, mount the power pack on the wall to the left or right of the pure water system where it is freely accessible.
- Stick the universal holder which is supplied in the assembly kit to the back of the power pack as shown in the above Figure.
- Stick the universal adapter to a smooth wall surface or screw it to the wall using the dowels and screws supplied in the assembly kit.
- When the universal holder and universal adapter have been fitted, hang the power pack in.
- Plug the connecting cable (appliance cable) in the power pack socket.
- Connect the power pack to the pure water system (48V DC 4-pin power supply connector, pos. 11).
- The system is now ready for use.

13. Operating elements

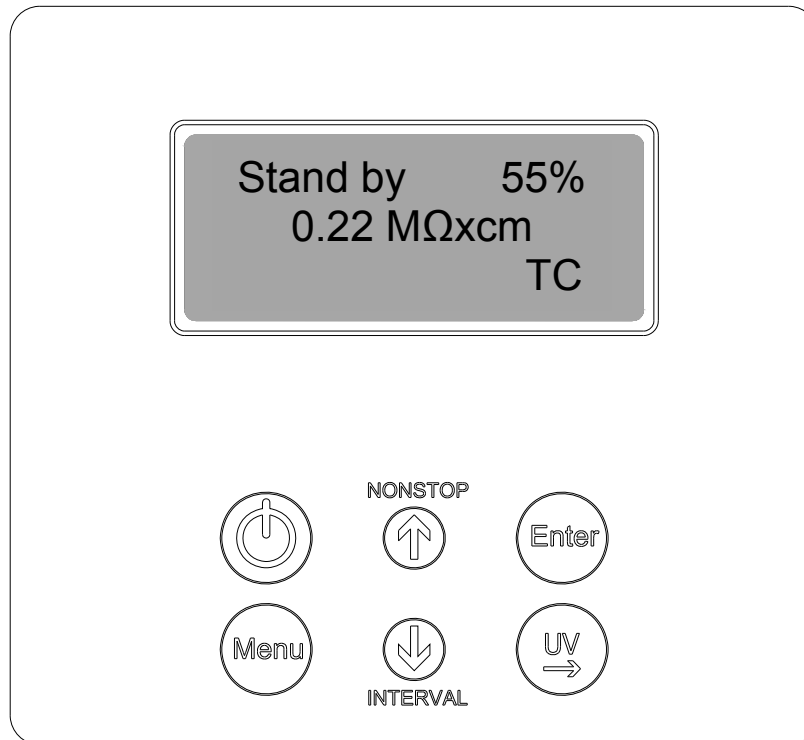

Switches the system on or off

NONSTOP



Increases a value on display



Confirms the value shown in a menu point



Switches the menu to the next menu point



Decreases a value on display

INTERVAL



Switches the UV-lamp on or, in the menu, allows you to select the position in a number that you wish to change

14. System control

General information

When the ON/OFF key is pressed, the pure water system starts running either in the operating mode or in the stand-by mode, as governed by the float switch.

The operating mode and the volume contained in the tank are shown in line 1 of the display and the measured value for the permeate is shown in line 2.

Should a fault exist, then a fault message is given out across the potential-free output and is shown in line 4 of the display. Should several faults occur simultaneously, then they are alternately displayed.

14.1 User menu

All of the measured values, operating times and limiting values that are relevant for the user can be set and read in this menu.

A press on the menu-key brings you into this menu. Each further press on the menu-key moves you on from one menu prompt to the next.

Settings can be changed with the arrow keys and, when the appropriate value has been set, be confirmed by pressing the Enter-key, which also takes you to the next menu prompt.

To simplify changing settings, a press on the UV-key allows you to select a certain number in the numerical value that you wish to change. The arrow-keys can then be used to enter the wanted number from 0 to 9 at the selected position.

14.1.1 Feedwater conductivity:

A single press on the menu-key enables the feedwater conductivity (measuring point LF3) to be read.

There is no limiting value evaluation here.

The display shows:

e.g.:

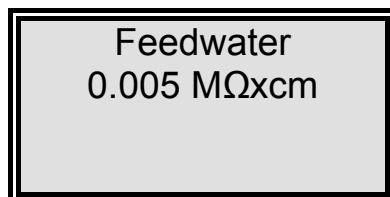

14.1.2 Permeate limiting value:

A second press on the menu-key allows the limiting value for the permeate conductivity to be set. Should this limiting value be exceeded, then the "*Lim.val.permeate*" fault message is displayed (measuring point LF 2)

Limiting value setting range: 1.0 – 99.0 $\mu\text{S/cm}$
Basic setting: 0.02 $\text{M}\Omega\text{cm}$

Use the arrow keys to set the limiting value (see 11.1). Settings above 99.0 $\mu\text{S/cm}$ result in the limiting value being switched off. The word "*Off*" appears in the display.

The display shows:

e.g.:

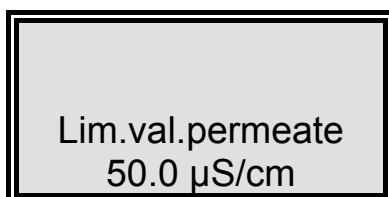

14.1.3 Operating hours: (is not active in this system version)

A third press on the menu-key in this menu brings the operating hours of the UV-lamp and the RO pump to display. The operating hours counter for the UV-lamp registers the time that the lamp has been in operation. When the maximum operating time is reached, then the fault message "*UV-Time*" is triggered. The limiting value of this is set in the OEM menu. The operating time of the RO pump has no limiting value.

The display shows:

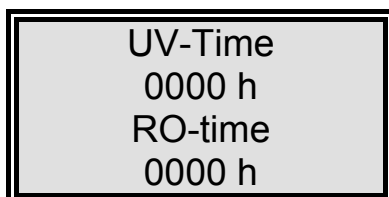

14.1.4 Operating hours, pretreatment:

A fourth press on the menu-key in this menu brings the operating hours of the pretreatment cartridge to display.

This operating time has a limiting value, which can be set in the UV menu. The fault message that is displayed when the limiting value is exceeded is "*Pretreatment*".

The operating hours of the pretreatment are counted whenever the reverse osmosis pump is running.

The display shows:

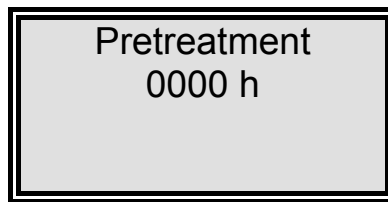

Pretreatment
0000 h

14.1.5 Cleaning:

A fifth press on the menu key in this menu allows cleaning to be triggered if necessary. Triggering is made by confirming the requirement with a press on the Enter-key. The pump is started and the inlet solenoid valve and the rinsing solenoid valve open for a 60 second period.

During cleaning, no fault messages or measured values are shown; when cleaning is finished, the system is in the last operating mode (operation or stand-by). During cleaning, the remaining cleaning time is displayed.

The display shows:

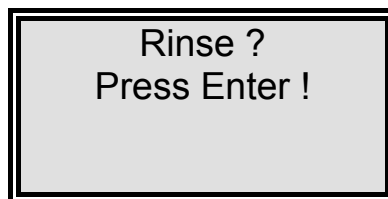

Rinse ?
Press Enter !

During cleaning, the display shows:



Rinse
30 sec.

14.1.6 Disinfection:
(is not active in this system version)

The display shows:



14.1.7 Fault storage:

A seventh press on the menu-key in this menu calls the fault storage prompt. Confirmation of this with the Enter-key allows the fault storage to be looked through. The display can show two faults at once, each with time and date. Pressing an arrow key allows previous or following faults to be displayed.

Pressing the menu-key or the Enter-key returns the system to the last operating mode.

The display shows:



Display of the contents of the fault storage:

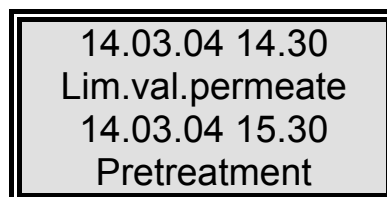

14.1.8 Unlocking the system:

An eighth press on the menu-key in this menu brings you to the “Code” menu. To prevent unauthorized access to the settings in the system control, changes to the settings can only be carried out when a correct code from the Assignment Table that follows is entered and confirmed with the Enter-key. The unlocking remains active for 5 minutes. Each access via the code is typed out by the printer (RS 232) complete with date, time and abbreviated code number (“Code 0001” corresponds to code 150, “Code 0002” to code 250 etc.).

The menu prompt F display shows:



Code
Press Enter !
0000



Code numbers can be assigned to individual persons according to the Assignment Table that follows on page 25.
Please remove this page from the Operating Instructions and store it where it is safe from unauthorized viewing.

Assignment Table for code numbers that allow the system to be unlocked

Code no.	Printer output	Person
150	00001	
250	0002	
350	0003	
450	0004	
550	0005	
650	0006	
750	0007	
850	0008	
950	0009	

14.2 OEM Menu

Basic settings and limiting values can be changed in this menu.

To make changes in the OEM menu, the system control must previously be unlocked (see 11.1.8 "Unlocking the system").

Calling the OEM menu:

Simultaneous pressing of the Interval-key and the Nonstop-key calls the OEM menu. Following this, the prompt "*OEM menu Press enter*" appears. When this is confirmed with the Enter-key, the first menu prompt can be worked on. To simplify changing settings, press the UV-key to select the number in a numerical value which you want to change. Now use the arrow keys to enter the wanted number from 0 to 9 at the selected position.

A press on the menu-key takes you to the next menu prompt.

The OEM menu call display shows:

A rectangular box with a double border containing the text "OEM menu" on the first line and "Press Enter !" on the second line.

OEM menu
Press Enter !

14.2.1 Maximum Temperatur:

A single press on the menu-key:

The maximum temperature which the system can be allowed to reach can be set in this menu. When this temperature is exceeded, the "*max. Temp.*" fault message is triggered. Settings above 50 °C cause the limiting value to be suppressed and the word „*off*“ appears in the 4th line of the display.

Basic setting: 50 °C

Setting range: 1 - 50 °C

The display shows:

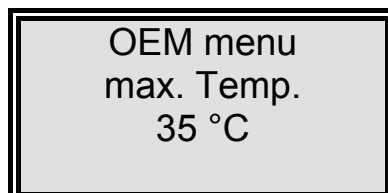
A rectangular box with a double border containing the text "OEM menu" on the first line, "max. Temp." on the second line, and "35 °C" on the third line.

OEM menu
max. Temp.
35 °C

14.2.2 Disinfection time:

A second press on the menu-key:
(not active in this system version)

The display shows:

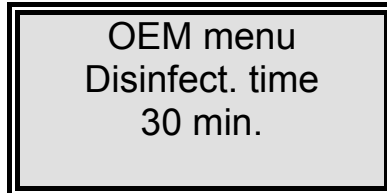

14.2.3 Recirculation time:

A third press on the menu-key:

The recirculation time is set in this menu.

Basic setting: 15 min.
Setting range: 1 - 30 min.

The display shows:

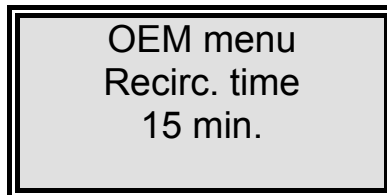

14.2.4 Rinsing time:

A fourth press on the menu-key:

The rinsing time is set in this menu.

Basic setting: 30 sec.
Setting range: 10 - 60 sec.

The display shows:

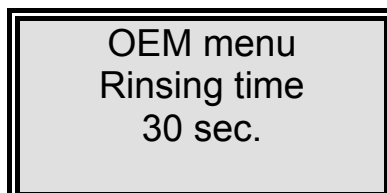

14.2.5 Interval rinse time:
A fifth press on the menu key:

The interval rinse time can be set in this menu. Rinsing is then carried out for this time period when the operating mode is changed, between stand-by and operation and every 12 hours.

Basic setting: 2 sec.
Setting range: 1 - 30 sec.

The display shows:

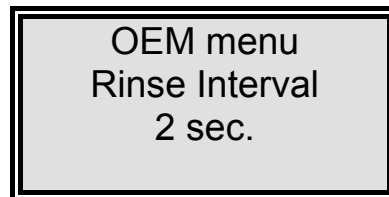

OEM menu
Rinse Interval
2 sec.

14.2.6 Real-time clock:
A sixth press on the menu-key:

The real-time clock is set in this menu.

Basic setting: The actual date and time
Setting range: Month 1 - 12. Day 1 - 31. Hour 0 - 24. Minute 0 - 60

The display shows:

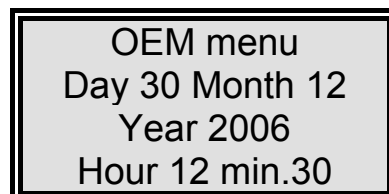

OEM menu
Day 30 Month 12
Year 2006
Hour 12 min.30

14.2.7 Sending interval:
A seventh press on the menu-key:

In this menu, the sending interval for transmissions of measured values and fault messages to the RS 232 interface can be set.

Basic setting: 1 hour
Setting range: 0.5 - 12 hours

The display shows:

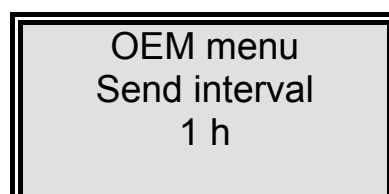

OEM menu
Send interval
1 h

14.2.8 Language:**An eighth press on the menu-key:**

The language in which the texts are displayed is set in this menu.
The choice is of English, German or French.

Basic setting: English

The display shows:

**14.2.9 Switching units:****A ninth press on the menu-key:**

In this menu, a choice can be made as to which unit is to be displayed, specific electric resistance or conductivity.

Basic setting: Resistance MΩxcm
Setting range: Resistance MΩxcm,
Specific electric resistance MΩxcm

The display shows:

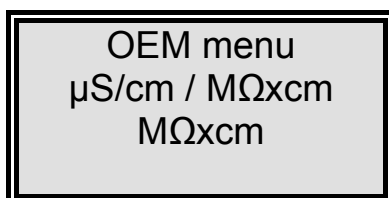
**14.2.10 Switch off temperature compensation:****A tenth press on the menu-key:****Basic setting: off**
Setting range: on, off

The display shows:

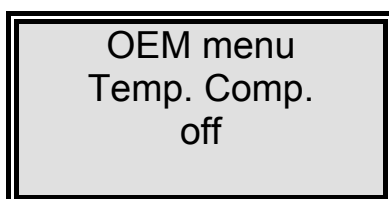

14.2.11 Adjusting the float switch circuit hysteresis:
An eleventh press on the menu-key:

Basic setting: **Off:** 100 %
 On: 70 %

Setting range: **Off:** 25 - 100 %
 On: 0 - 70 %

With a setting of above 100 % for the upper switching point, the display of the tank level is switched off, so that this setting shows whether an analogue or a digital float switch is installed.

The display shows:

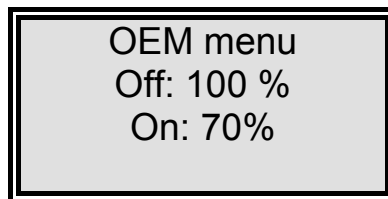

OEM menu
Off: 100 %
On: 70%

14.2.12 Programme choice TII UV/ RO:
A twelfth press on the menu-key:

The equipping grade of the system can be set in this menu so that a differentiation can be made between TII UV and RO versions.

Basic setting: RO

The display shows:



OEM menu
Version
RO

14.2.13 Entering the system type and serial number:

The system type and serial number can be entered in this menu. They are both then printed as headline on every print-out. The following types of system can be entered:
Pacific RO / Pacific TII / Pacific TII UV / Pacific AFT

The display shows:

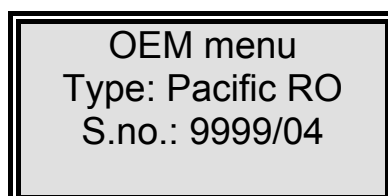

OEM menu
Type: Pacific RO
S.no.: 9999/04

14.3 Printer output

Various parameters can be recorded by means of a printer. A distinction is made between three types of messages:

- Standard messages
- Code messages
- Fault messages

14.3.1 Standard messages:

A record of all measured values is printed out here in dependence on the sender interval.

Print-out:

```
e.g.:          31.10.07 09:39
                Pacific RO
                S.No. 9999/07
                TC off UV off
                LF2=  0.220 MΩxcm
                LF3=  0.005 MΩxcm
                Temp.= off
```

14.3.2 Code messages:

Whenever a code number is entered in the system control and confirmed with the Enter-key, then the code input is immediately printed out.

For code identification refer to the „Assignment Table for code numbers that allow the system to be unlocked”.

Print-out:

```
e.g.:          31.10.07 10:17
                Pacific RO
                S.No. 9999/07
                Code 0001
```

14.3.3 Fault messages:

Should a fault message be shown in the display, e.g. for the permeate limiting value, then this fault message is printed out after the sending interval.

Print-out:

```
e.g.:          31.10.07 16:15
                Pacific RO
                S.No. 9999/07
                Lim.val.permeate
```

15. Maintenance

Regular servicing of your system ensures that the worth of it is maintained. We recommend that you secure a service contract with a service company expressly authorised to ensure that maintenance work that is required twice yearly is carried out. You then have the certainty of a high operational safety and reliability of your system.

To ensure your system reliably for a long time, it must be checked, serviced and cared for at regular time intervals in accordance with these operating instructions! For this reason, the operating instructions must be readily available to operating and maintenance staff at all times, and be carefully followed!

Any maintenance work which should become necessary during the validity of the guarantee is only to be carried out by a service professional expressly authorized to do such work.

The operating-staff assigned is committed to carry out the weekly checks. During the agreed term of validity of the guarantee, maintenance is to be carried out weekly according to the maintenance record supplied with the operating instructions.

Calibration of the conductivity is only to be carried out and recorded by customer service.

Cleaning and disinfection of your system is performed for reasons of hygiene and has no effect on the technical condition of the system. The system must be cleaned and disinfected at least once yearly.



Control and maintenance work on electrical systems are only to be carried out when the system has been switched currentless at the mains and the switching has been secured against inadvertent switching back on. Such work is only to be performed by an appropriately trained, skilled electrician.

15.1 Maintenance intervals

Consumable materials are to be replaced at the intervals given in the following Table or when there is a drop in performance:

Material	Flow chart no.	Article no.	Interval*
Pretreatment 09.4001 Prefilter/Hardness stabilization	F1	06.5204	6 Months
Pretreatment 09.4000 Prefilter Hardness stabilization	F1	06.5201 06.5452	6 Months 6 Months
Filter cartridge	F3	09.4011/09.4012	12 Months

*Please keep in mind that the life of your consumables is directly dependent on the quality of the feed water and the amount of water used daily. The interval is contingent on the feedwater quality so that a shorter one may be necessary.

15.2 Rinsing membranes

Rinsing out preservative solution:

According to the mode of delivery, the system may be filled with a solution containing a preservative. When putting the system into operation, it is important to discard the permeate that is produced for at least 3 – 4 hours after switching to production.

To do this, after each filling of the tank, open the tap at your withdrawal position and allow the pure water that has been produced to flow to drain.

Cleaning membranes:

Automatic rinsing lengthens the service life of your reverse osmosis module. Coarse particles and other contaminants are swept away from the membrane surface during this rinsing process. The rinsing phases so ensure the longest service life and optimal pure water quality.



Leave your pure water system on over the weekend and during holiday times. Only then can the 12-hourly rinse operate and ensure that your reverse osmosis module is not subject to bacterial growth during standstill periods.

Should the performance of your module drop because operation of the system without an appropriate pretreatment has resulted in membrane blockage, it may well be that your module can be reconditioned.

Reconditioning and disinfection of the module is only to be carried out by authorized service personnel on-site or by sending the module to the manufacturer of your pure water system, whereby exposure to frost must be avoided.

15.3 Replacing the pretreatment

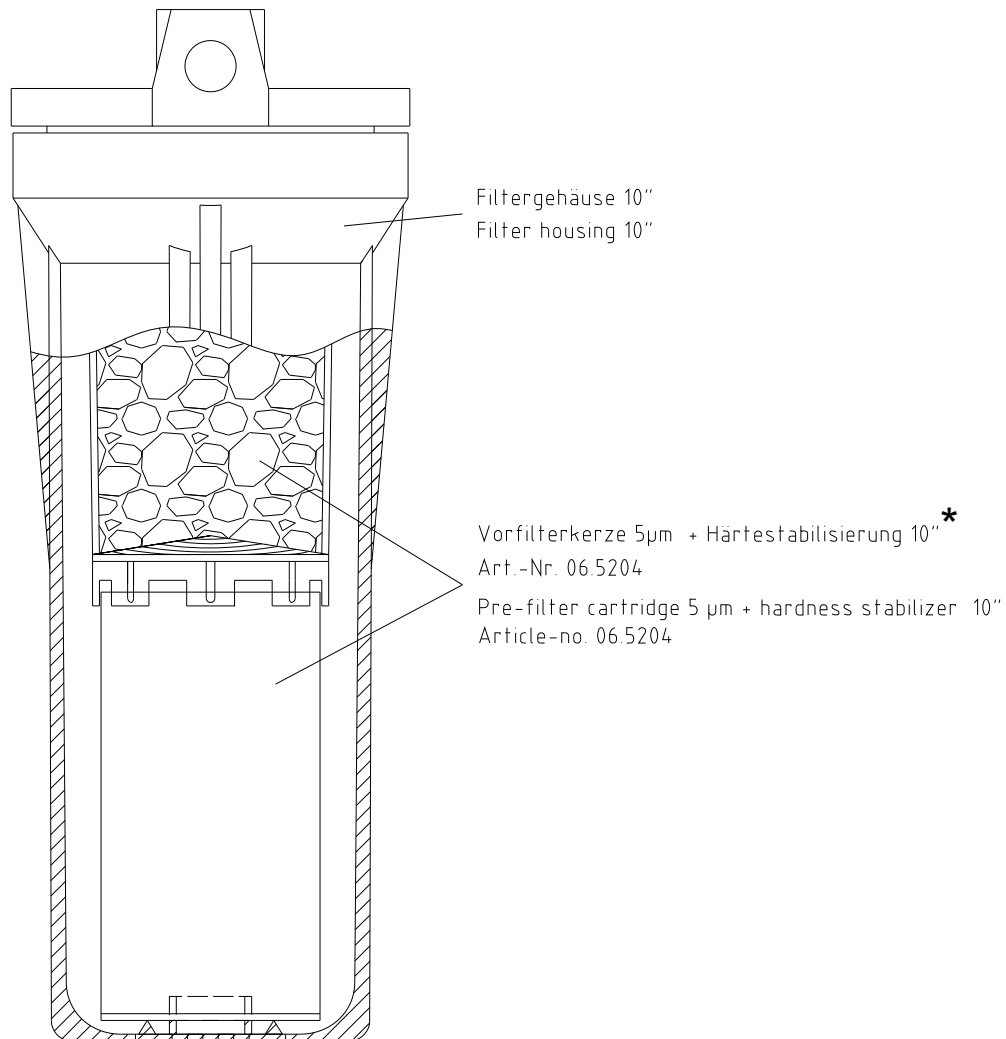

1. Remove the covering hood from the storage tank.
2. Open the residual drainage of the storage tank until the pure water system starts to operate.
3. Shut off the supply of feedwater to the pure water system.
4. Switch the system off.
5. Turn the residual drainage to close it again.
6. Screw the pretreatment filter housing off.
Caution! The filter housing is still full of water.
7. Change spent pretreatment unit.
8. Screw the filter housing back on.

9. Open the supply of feedwater to the system.
10. Check that the filter housing does not leak.
11. Switch the pure water system back on.
12. Replace the covering hood on the storage tank.

Your pure water system is now again ready for use.

15.4. Replacing the RO-membranes

LabTower TII/TII UV 60:

2 RO Membranes 22.0087 front modul (complete)
2 RO Membranes 22.0046 backmost modul (complete)

Ansicht von hinten - ohne Rückwand
Back view, with back panel removed

Modul komplett
Modul complete

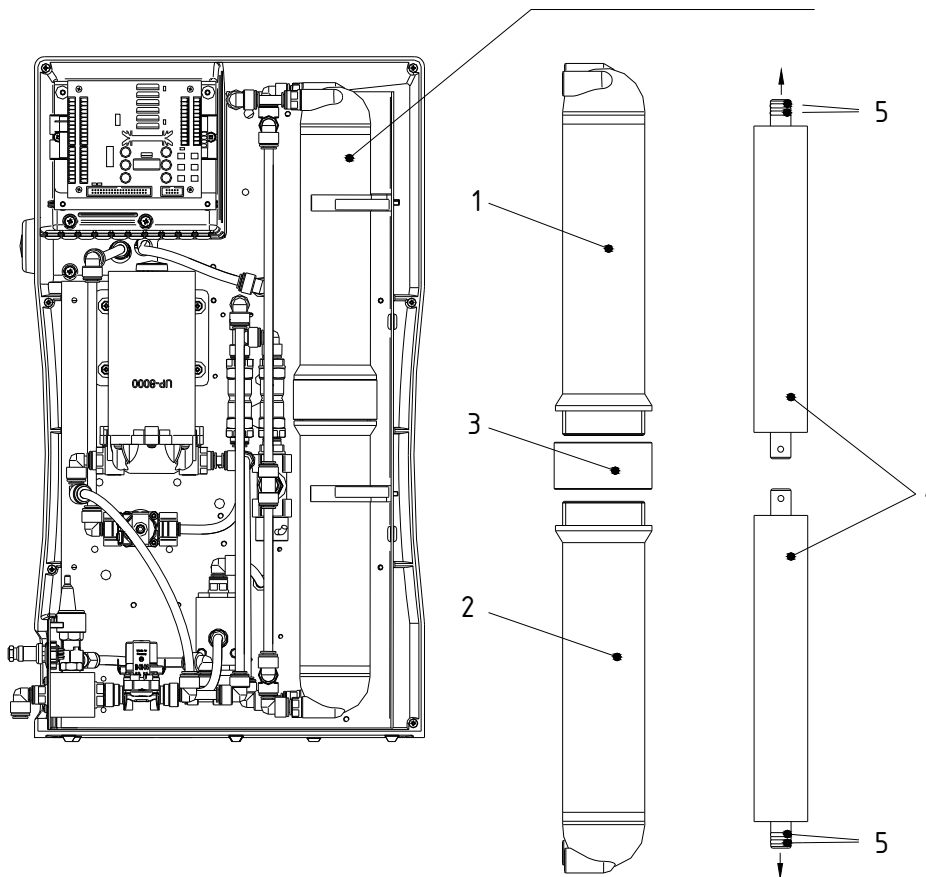

- Unplug the mains plug.
- Remove the back panel.
- Release all hose connections to the modul (complete) of the RO-module.
- Take the modul (complete) out of the holding sleeves.
- Open the pressure tube socket (3) between pressure tube upper component (1) and pressure tube bottom part (2) and remove the membrane unit (4).
- Insert the new membrane unit with the O-rings (5) on the permeate tube in the direction of the arrow pointing to the pressure tube upper component (1) and pressure tube bottom part (2) and screw in pressure tube (1,2) again.



Insertion of RO-membranes the wrong way round would lead to certain destruction of them!

**It is to respected that the connections of the Fittinge to each other due pres-
sure tubes in the same angle is to each to other aligned.**

15.5 Changing the filter cartridge

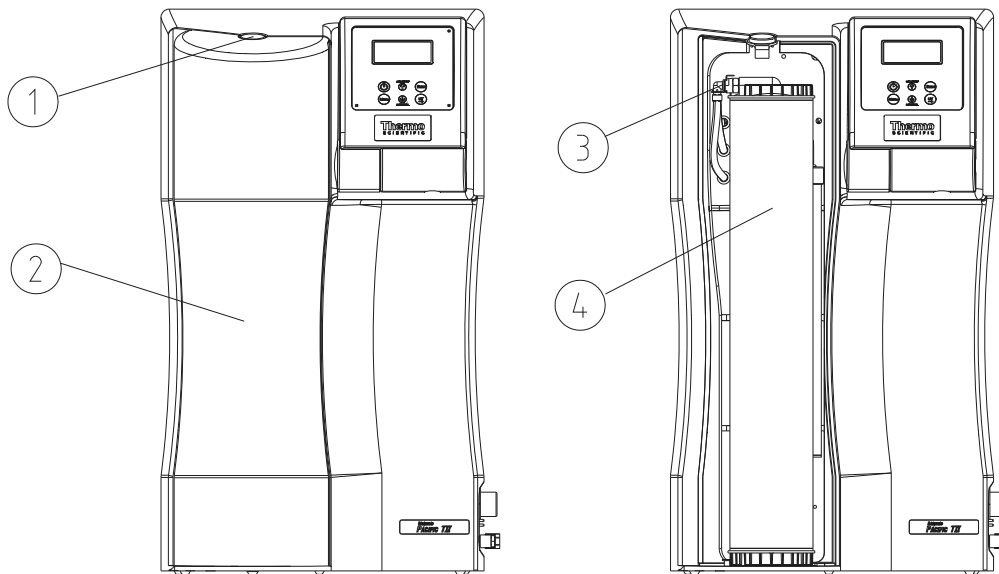

For changing the filter cartridge, proceed as follows:

1. Switch off your device and turn off the feedwater supply.
2. Press pressure knob (1) to unlock and remove cover (2).
3. Release filter cartridge (4) quick connect coupling (3).
4. Remove exhausted filter cartridge (4) and replace it with a new one.
5. Fit the quick connect coupling (3) back onto the new filter cartridge (4).
6. Replace the cover (2) and listen to ensure it clicks on pressure knob (1).
7. Turn on the feedwater supply and switch your device on again.
8. Your device is now ready for operation

15.6 Disinfection

Disinfection of storage tank



Your system should be cleaned and disinfected at least once a year to eliminate any bacteria that are possibly in the system. We recommend that you carry out cleaning and disinfection shortly before the time that the filter cartridge must to be replaced.

Use cleaning solutions as follows:

MICRO-Chlor Granulate, 1 box, article no. 09.2202 (Europe only)

Cleaning Solution, 1 syringe, article no. CMX 25 (US-market only).



Please observe the information given in the safety data sheet supplied with Micro-Chlor disinfectant to avoid possible health hazards!

1. The pure water system must be in the “Stand by” operating mode. The storage tank must be filled.
2. Switch the system off and unplug the power supply from the pure water system.
3. Turn off the feedwater supply to the system.
4. Open the dispensing valve to bleed the pure water system completely and then close it again.
5. Remove the covering hood from the storage tank.
6. Remove the four connectors from the pure water system to the storage tank and pull the 8 pin connector (float switch, pressure pump, (see Chapter 11. Putting the system into operation).
7. Lift the system from the storage tank and put it aside.
8. Remove the table by removing the 3 screws.
9. Open the lid of the storage tank, pour the contents of a box respectively a syringe of then cleaning solution in the water-filled tank and then close the lid.
10. Leave the disinfectant for 1 hour in the storage tank..



Do not take any water from the dispensing valve or the storage tank during disinfection.

11. Now open the residual drainage of the storage tank and discard all of the water. Close the residual drainage.
12. Screw the table back to the storage tank.

13. Replace the pure water system back to the storage tank and connect the four connectors for power supply and the 8 pin connector (float switch, pressure pump) to the storage tank.
14. Open the feedwater supply to the system.
15. Switch the pure water system on.
16. Fill the storage tank until the “Stand by” operating mode has been reached and empty the tank as in 11. Repeat this process a second time.
17. Finally replace the covering hood on the storage tank.
18. The pure water system is now again at your availability to produce pure water.

16. Waste disposal

When the packaging is no longer needed it can be disposed of as household waste.

Systems are in conformity with EEC Guideline 2002/95/EC

The system is not to be thrown away as household waste but must be properly disposed of. It can be returned to the manufacturer for safe disposal according to EEC Guideline 2002/96/EC. We therefore request our customers in Germany and other member States in the European Economic Area to contact our local service centre or our headquarters:

Thermo Electron LED GmbH
Stockland 3
D-56412 Niederelbert, Germany

WEEE-Reg.-no.: DE 12471402

In countries outside of the European Economic Area, please contact your local authorities or waste disposal company.

17. Trouble shooting

Fault	Cause	Remedy
The system does not start	- No supply of power	- Supply power
No dispensing possible	- Feedwater tap is closed - Feedwater and rinse water connections mixed up - Feedwater pressure < 1.5 bar	- Open the feedwater tap - Switch connections - Increase feedwater pressure
System control no longer reacts	- Improper operation	- Unplug the mains plug for 5 seconds
Water leaks out	- Leaky hose connection - Feedwater pressure > 6 bar	- Check hose connection, find and stop leak - Install an upstream pressure reducer
Permeate flow too low (-15%)	- Blocked membrane - Pre-pressure too low - Feedwater temperature fluctuates	- Clean the membrane - Increase the pre-pressure
Wrong time or date	- Time zone - Summer/Winter time	- Set to correct time or date
Wrong language	- Wrong language set	- Correct the language setting
Fault message: <i>"Lim.val.permeate"</i>	- The permeate conductivity is too high - Limiting value set too low - Membrane blocked	- Check the pretreatment - Check and adjust limiting value setting - Replace membrane

<p>Fault message: <i>"Measuring cell LF2"</i></p>	<ul style="list-style-type: none"> - Break in measuring cell cable - System control defect - Permeate conductivity outside the measuring range 	<ul style="list-style-type: none"> - Replace the measuring cell - Replace the system control - See permeate limiting value
<p>Fault message: <i>"Measuring cell LF3"</i></p>	<ul style="list-style-type: none"> - Break in measuring cell cable - System control defect 	<ul style="list-style-type: none"> - Replace the measuring cell - Replace the system control

The address to contact when your system requires service:

Overview of Thermo Scientific International Sales Organization

Postal address USA:

Thermo Scientific
275 Aiken Road
Asheville, NC 28804
USA

Enquiries from USA/Canada

Sales: +1 866 984 3766
Service: +1 800 438 4851

Enquiries from Latin America

Sales: +1 866 984 3766
Service: +1 866 984 3766

Enquiries from Asia

China

Sales: +86 10 8419 3588
Service: Toll free 8008105118
Support Mobile 4006505118 or +86 10 8419 3588

India

Sales: +91 22 6716 2200
Service: Toll free 1 800 22 8374 or +91 22 6716 2200

Japan

Sales: +81 45 453 9220
Service: +81 45 453 9224

Enquiries from the Rest of Asia/Australia/New Zealand

Sales: +852 2885 4613
Service: +65 6872 9720

Enquiries from Countries not listed / Rest of EMEA

Sales: +49 6184 90 6940 or +33 2 2803 2000
Service: +49 6184 90 6940

Enquiries from Europe**Austria****Sales:** +43 1 801 40 0**Service:** +43 1 801 40 0**Belgium****Sales:** +32 53 73 4241**Service:** +32 53 73 4241**Finland/Nordic/Baltic countries****Sales:** +358 9 329 100**Service:** +358 9 329 100**France****Sales:** +33 2 2803 2180**Service:** +33 825 800 119**Germany:****Postal Address Germany:**

Thermo Electron LED GmbH

Robert-Bosch-Straße 1

D - 63505 Langenselbold

Phone**Sales:** Toll free 0800 1 536 376

or +49 6184 90 6940

Service: Toll free 0800 1 112110

or +49 6184 90 6940

E-Mail: I info.labequipment.de@thermoftsher.com**Italy****Sales:** +39 02 95059 341**Service:** +39 02 95059 250**Netherlands****Sales:** +31 76 579 5555**Service:** +31 76 579 5639**Russia/CIS****Sales:** +7 812 703 4215**Service:** +7 812 703 4215**Spain/Portugal****Sales:** +34 93 223 0918**Service:** +34 93 223 0918**Switzerland****Sales:** +41 44 454 1212**Service:** +41 44 454 1212**UK/Ireland****Service:** +44 870 609 9203**Sales:** +44 870 609 9203

18. List of replacement parts

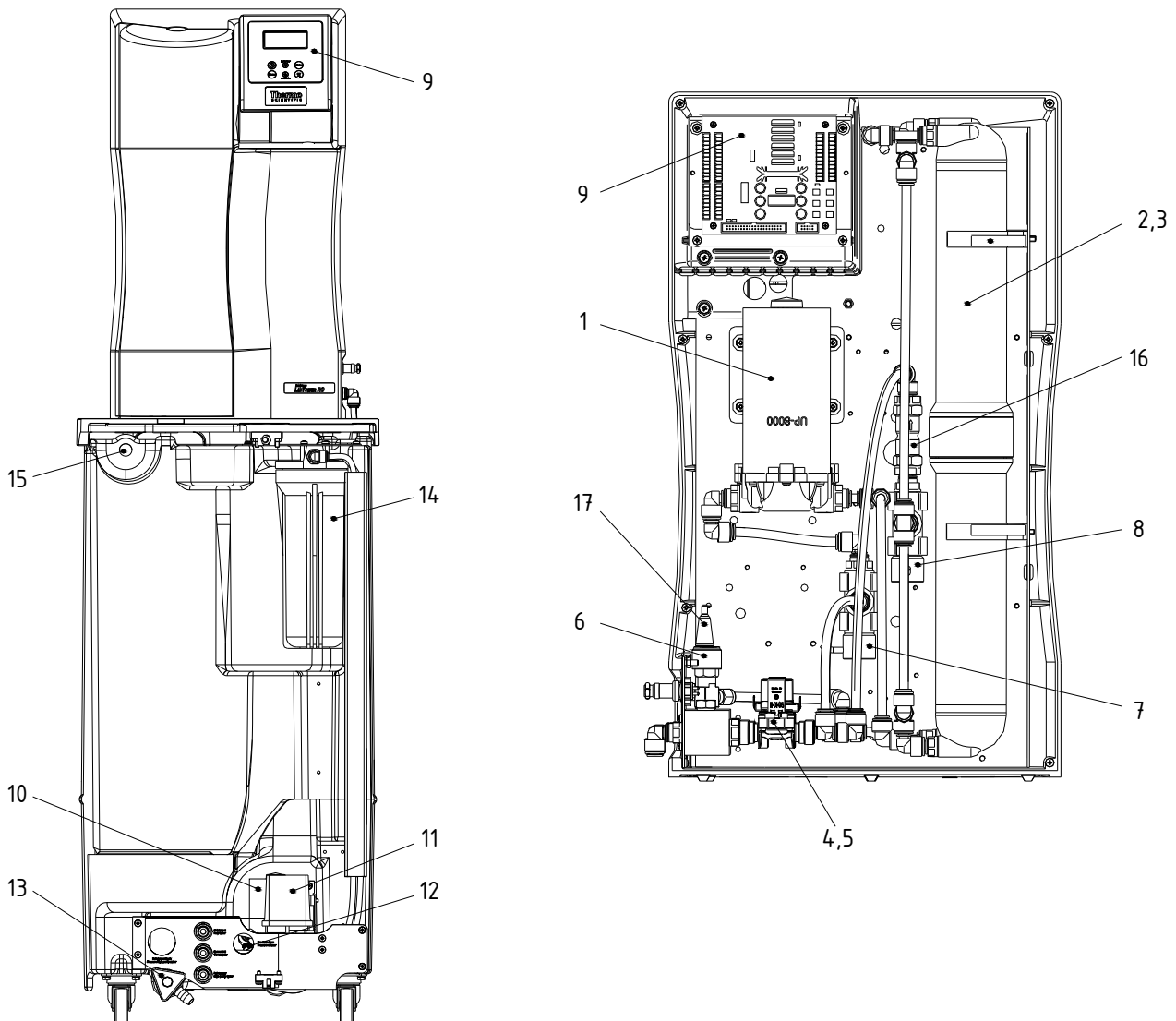

Parts marked with an "x" are wear parts.

Pos.	Flow chart no.	Designation	Article no.	
1	P1	Pressure booster pompe	19.0050	x
2	F2	RO – Module complete	50133987	
3	F2	RO - Module, RO membrane: 2 x 1812-75 2x1812-100	22.0046 22.0087	x x
4	V1	Inlet, solenoid valve	50131190	x
5	V4	Rinsing, solenoid valve	50131190	x
6	V3	Pressure hold valve	15.0060	
7	QIA300	Measuring cell, feedwater	16.0126	
8	QIA301	Measuring cell, pure water	16.0126	
9		Microprocessor system control, complete	50132019	
10	P2	Booster pump	19.0046	x
11	PS200	Pressure switch	15.0058	x

12	V7	Check valve	14.0441	
13	V5	Dispensing valve/ residual drainage	14.0250	
14	F1	Prefilter, consisting of: Prefilter cartridge 5µm + Hardness stabilization, 10"	06.5204	
15	F3	Sterile vent filter, 0.2µm (option)	06.5003	
16	V2	Check valve	15.0009	
17		Holder for glas tube fuse, 5 x 20 mm Glas tube fuse, 5 x 20 mm, 2 A, nimble	50133979 50134191	
		Table power unit 48V DC (not shown)	50134184	



We ask for your understanding that the guarantee we give becomes invalid when replacement parts, accessories or consumables from other manufacturers are used, as we have no influence on their appropriateness or quality.

19. Consumable materials

Article designation	Article no.
Pretreatment:	
Prefilter cartridge 5µm + hardness stabilization, 10"	06.5204
Fine filter 1µm-10"	06.5101
Sterile vent filter	06.5003
UV-Emitter, storage tank:	
Replacement UV-lamp	22.0095
Immersion tube	22.0096

20. Accessories

Article designation	Article no.
UV-Emitter (in the storage tank)	06.5006
Sterile vent filter	06.5003
Sterile overflow	50132714
Pretreatment, consisting of: 1x activated carbon combi cartridge 5µm, 10" 1x hardness stabilizing cartridge 10"	09.4000
Pretreatment, consisting of: 1x activated carbon combi cartridge 5µm, 5" 1x hardness stabilizing cartridge 5"	09.4001
Disinfection agent, MICRO-Chlor (pack of 12 cans, Europe only)	09.2202
Cleaning Solution, 1 syringe (US-market only)	CMX25
Pressure pump MQ3 – 35, 110V	50135134
Pressure pump MQ3 – 45, 110V	50135135

21. Terminal assignment

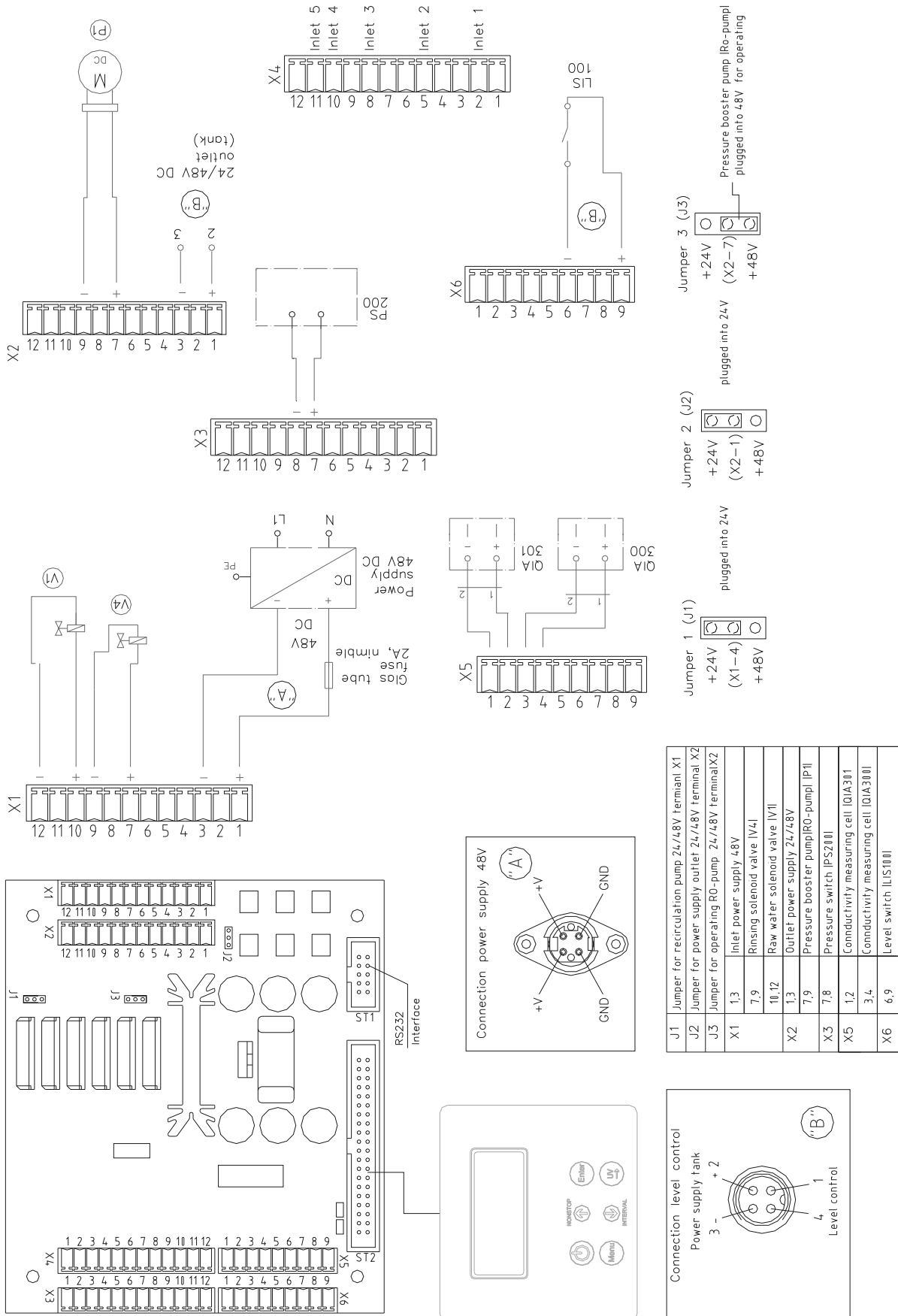

22. Maintenance record

(Please keep carefully up-to-date as this is one of the conditions of the guarantee)

Customer address: _____ Installation location: _____

System type: _____

Serial no.: _____

Year made: _____

Date	Feedwater resistance [MΩxcm]	Permeat resistance [MΩxcm]	Prefilter replaced yes/no	Hardness stabilization replaced yes/no	Signature

Any false entry is considered to be a falsification of documents.

The following points are to be observed to ensure the quality of the system:

- 1 x weekly, record measured values.

Contact Information Thermo Scientific

North America:

USA/Canada +1 866 984 3766 (866-9-THERMO)

Europe:

Austria +43 1 801 40 0, Belgium +32 53 73 42 41, France +33 2 2803 2180,
Germany national toll free 08001-536 376,
Germany international +49 6184 90 6940, Italy +39 02 95059 448,
Netherlands +31 76 579 55 55, Nordic/Baltic/CIS countries +358 9 329 10200,
Russia +7 812 703 42 15, Spain/Portugal +34 93 223 09 18,
Switzerland +41 44 454 12 12, UK/Ireland +44 870 609 9203

Asia:

Australia +61 39757 4300, China +86 21 6865 4588 or +86 10 8419 3588,
India toll free 1800 22 8374, India +91 22 6716 2200,
Japan +81 45 453 9220, New Zealand +64 9 980 6700,
Other Asian countries +852 2885 4613

Countries not listed: +49 6184 90 6940